

Sample Question Paper (TERM – I) 2021-22

Class X
Science (086)

Time: 90 Minutes

General Instructions:

1. The Question Paper contains three sections.
2. Section A has 24 questions. Attempt any 20 questions.
3. Section B has 24 questions. Attempt any 20 questions.
4. Section C has 12 questions. Attempt any 10 questions.
5. All questions carry equal marks.
6. There is no negative marking.

SECTION - A

Section – A consists of 24 questions. Attempt any 20 questions from this section.

The first attempted 20 questions would be evaluated.

1. Reema took 5ml of Lead Nitrate solution in a beaker and added approximately 4ml of Potassium Iodide solution to it. What would she observe?
- A. The solution turned red.
 - B. Yellow precipitate was formed.
 - C. White precipitate was formed.
 - D. The reaction mixture became hot.

2. Identify gas A in the following experiment.

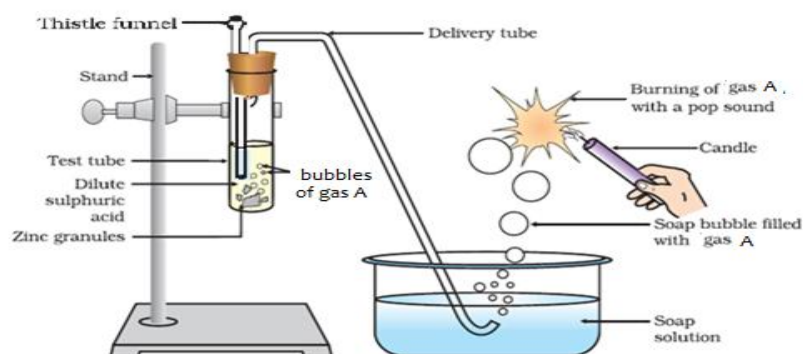

- A. Nitrogen
- B. Hydrogen
- C. Oxygen
- D. Carbon dioxide

3.

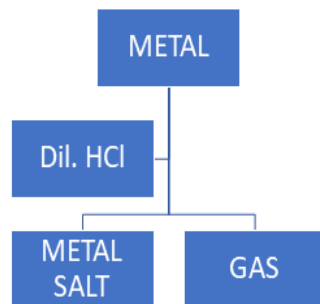

Which of the following two combinations are correct?

	Metal	Gas Evolved
(i)	Copper	Yes
(ii)	Iron	Yes
(iii)	Magnesium	No
(iv)	Zinc	Yes

- A. i and iii
- B. i and iv
- C. ii and iii
- D. ii and iv

4.

Which of the following correctly represents a balanced chemical equation?

- A. $\text{Fe(s)} + 4\text{H}_2\text{O(g)} \rightarrow \text{Fe}_3\text{O}_4\text{(s)} + 4\text{H}_2\text{(g)}$
- B. $3\text{Fe(s)} + 4\text{H}_2\text{O(g)} \rightarrow \text{Fe}_3\text{O}_4\text{(s)} + 4\text{H}_2\text{(g)}$
- C. $3\text{Fe(s)} + \text{H}_2\text{O(g)} \rightarrow \text{Fe}_3\text{O}_4\text{(s)} + \text{H}_2\text{(g)}$
- D. $3\text{Fe(s)} + 4\text{H}_2\text{O(g)} \rightarrow \text{Fe}_3\text{O}_4\text{(s)} + \text{H}_2\text{(g)}$

5.

The graph given below depicts a neutralization reaction (acid + alkali \rightarrow salt + water). The pH of a solution changes as we add excess of acid to an alkali.

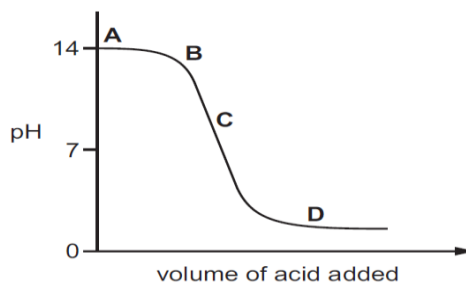

Which letter denotes the area of the graph where both acid and salt are present?

- A. A
- B. B
- C. C
- D. D

6. In the reaction of iron with copper sulphate solution:

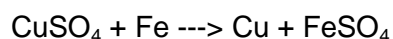

Which option in the given table correctly represents the *substance oxidised* and the *reducing agent*?

OPTION	Substance Oxidized	Reducing Agent
A	Fe	Fe
B	Fe	FeSO ₄
C	Cu	Fe
D	CuSO ₄	Fe

7. The chemical reaction between copper and oxygen can be categorized as:

- A. Displacement reaction
- B. Decomposition reaction
- C. Combination reaction
- D. Double displacement reaction

8. Which of the given options correctly represents the *Parent acid* and *base* of Calcium Carbonate?

OPTION	PARENT ACID	PARENT BASE
A	HCl	NaOH
B	H ₂ CO ₃	Ca(OH) ₂
C	H ₃ PO ₃	CaSO ₄
D	H ₂ SO ₄	CaSO ₄

9. How will you protect yourself from the heat generated while diluting a concentrated acid?

- A. By adding acid to water with constant stirring.
- B. By adding water to acid with constant stirring.
- C. By adding water to acid followed by base.
- D. By adding base to acid with constant stirring.

10. Why is it important to balance a skeletal chemical equation?

- A. To verify law of conservation of energy.
- B. To verify the law of constant proportion.
- C. To verify the law of conservation of mass.
- D. To verify the law of conservation of momentum.

11. Carefully study the diagram of the human respiratory system with labels A, B, C and D. Select the option which gives correct identification and main function and /or characteristic.

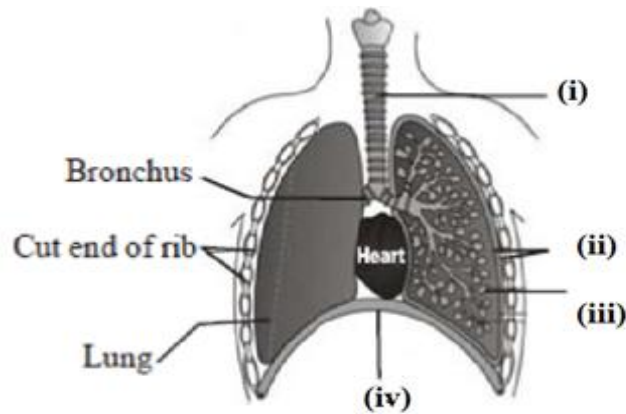

- A. (i) Trachea: It is supported by bony rings for conducting inspired air.
 B. (ii) Ribs: When we breathe out, ribs are lifted.
 C. (iii) Alveoli: Thin-walled sac like structures for exchange of gases.
 D. (iv) Diaphragm: It is pulled up when we breathe in.

12. Identify the option that indicates the correct enzyme that is secreted in location A, B and C.

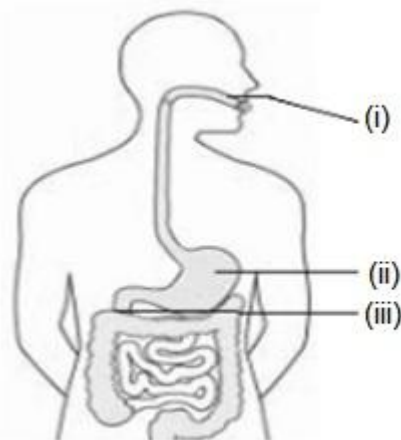

- A. (i)-lipase, (ii)-trypsin, (iii)-pepsin
 B. (i)-amylase, (ii)-pepsin, (iii)-trypsin
 C. (i)-trypsin, (ii)-amylase, (iii)-carboxylase
 D. (i)-permease, (ii)-carboxylase, (iii)-oxidase

13. Opening and closing of stomatal pore depends on:
- A. Atmospheric temperature
 - B. oxygen concentration around stomata
 - C. carbon dioxide concentration around stomata
 - D. water content in the guard cells

14. The figure given below shows a schematic plan of blood circulation in humans with labels (i) to (iv). Identify the correct label with its functions?

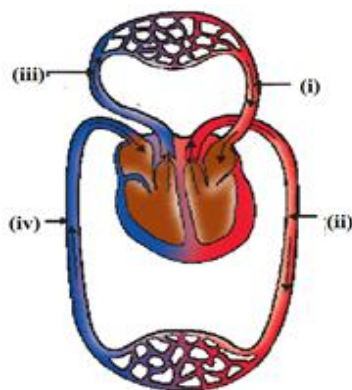

- A. (i) Pulmonary vein - takes impure blood from body part.
- B. (ii) Pulmonary artery - takes blood from lung to heart.
- C. (iii) Aorta - takes blood from heart to body parts.
- D. (iv) Vena cava takes - blood from body parts to right auricle.

15. Identify the phase of circulation which is represented in the diagram of heart given below. Arrows indicate contraction of the chambers shown.

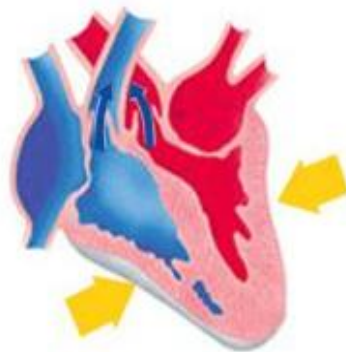

- A. Blood transferred to the right ventricle and left ventricle simultaneously.
- B. Blood is transferred to lungs for oxygenation and is pumped into various organs simultaneously.
- C. Blood transferred to the right auricle and left auricle simultaneously.
- D. Blood is received from lungs after oxygenation and is received from various organs of the body.

16. Observe the diagram of Human digestive system.

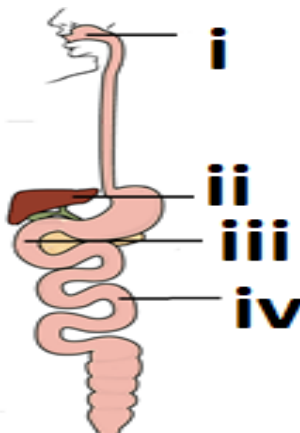

Match the labeling referred in column I and correlate with the function in column II.

Column I	Column II
i	a. The length of this depends on food the organism eats.
ii	b. Initial phase of starch digestion
iii	c. Increases the efficiency of lipase enzyme action
iv	d. This is the site of the complete digestion of carbohydrates, proteins and fats.

- A. i.- a) ; ii – b) ; iii – c) ; iv- d)
- B. i.- b) ; ii – c) ; iii – d) ; iv- a)
- C. i.- b) ; ii – d) ; iii – c) ; iv- a)
- D. i.- d) ; ii – a) ; iii – b) ; iv- c)

17. Which of the following mirror is used by a dentist to examine a small cavity in a patient's teeth?

- A. Convex mirror
- B. Plane mirror
- C. Concave mirror
- D. Any spherical mirror

18.

Which diagram shows image formation of an object on a screen by a converging lens?

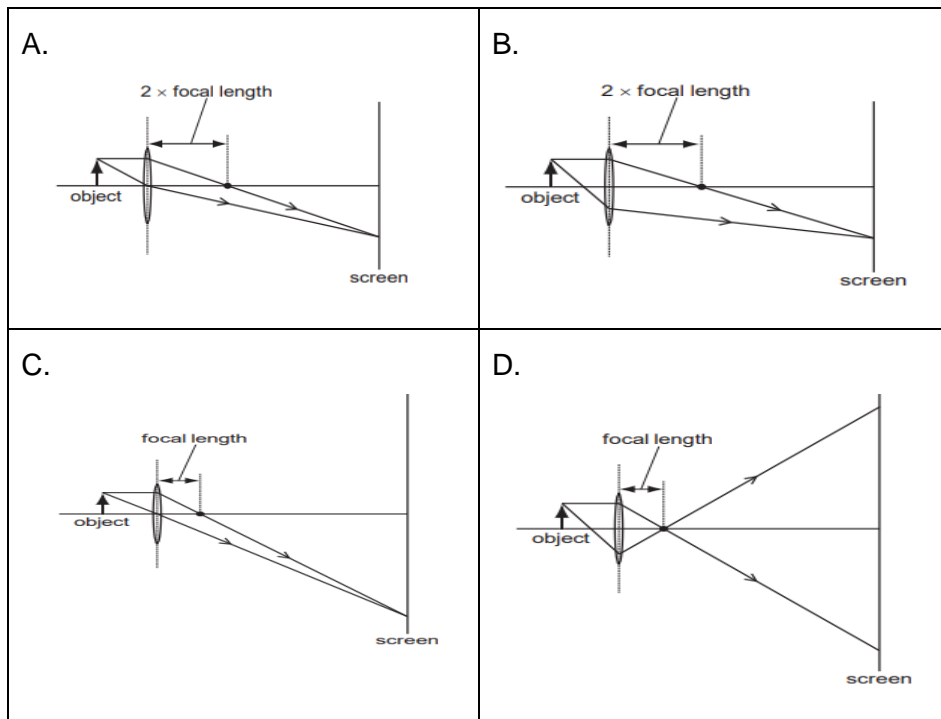

19.

Which of the following can make a parallel beam of light when light from a point source is incident on it?

- A. Concave mirror as well as convex lens.
- B. Convex mirror as well as concave lens.
- C. Two plane mirrors placed at 90° to each others.
- D. Concave mirror as well as concave lens.

20.

Consider these indices of refraction: glass: 1.52; air: 1.0003; water: 1.333. Based on the refractive indices of three materials, arrange the speed of light through them in decreasing order.

- A. The speed of light in water $>$ the speed of light in air $>$ the speed of light in glass.
- B. The speed of light in glass $>$ the speed of light in water $>$ the speed of light in air.
- C. The speed of light in air $>$ the speed of light in water $>$ the speed of light in glass.
- D. The speed of light in glass $>$ the speed of light in air $>$ the speed of light in water.

21.

If a beam of red light and a beam of violet light are incident at the same angle on the inclined surface of a prism from air medium and produce angles of refraction r and v respectively, which of the following is correct?

- A. $r = v$
- B. $r > v$
- C. $r = 1/v$
- D. $r < v$

22.

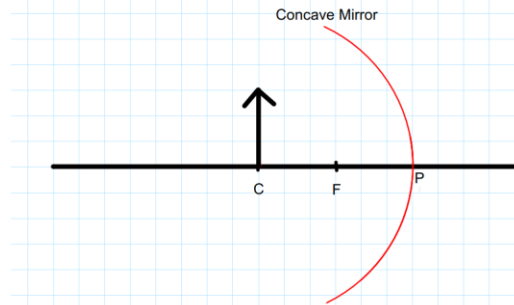

Examine the above figure and state which of the following option is correct?

[one small box in the figure is equal to 1 cm]

- A. The mirror has a focal length of -6 cm and will produce an image of magnification +1.
- B. The mirror has a focal length of -3 cm and will produce an image of magnification -1.
- C. The mirror has a focal length of -3 cm and will produce an image of magnification +1.
- D. The mirror has a focal length of -6 cm and will produce an image of magnification -1.

23.

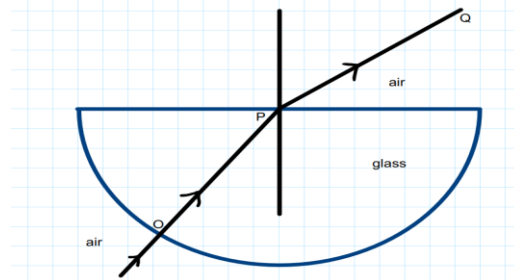

The angle of incidence from air to glass at the point O on the hemispherical glass slab is.

- A. 45°
- B. 0°
- C. 90°
- D. 180°

24.

A prism ABC (with BC as base) is placed in different orientations. A narrow beam of white light is incident on the prism as shown in below Figure. In which of the following diagrams, after dispersion, the third colour from the top of the spectrum corresponds to the colour of the sky?

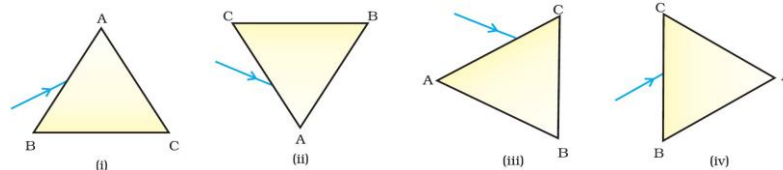

- A. (i)
- B. (ii)
- C. (iii)
- D. (iv)

SECTION - B

Section - B consists of 24 questions (Sl. No.25 to 48). Attempt any 20 questions from this section. The first attempted 20 questions would be evaluated.

25.

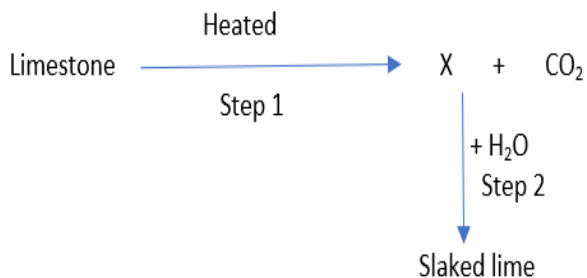

Identify the correct option from the given table which represents the type of reactions occurring in step 1 and step 2.

	endothermic	exothermic
A	x	✓
B	✓	x
C	✓	✓
D	x	x

26. In which year is concentration of hydrogen ion the highest?

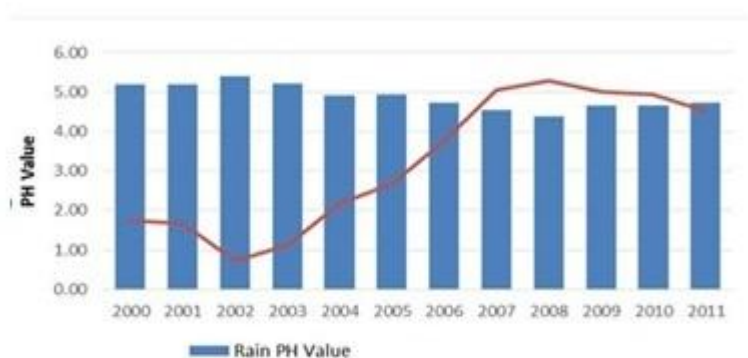

- A. 2002
- B. 2008
- C. 2011
- D. 2005

27.

The diagram shows the reaction between metal and dil. acid.

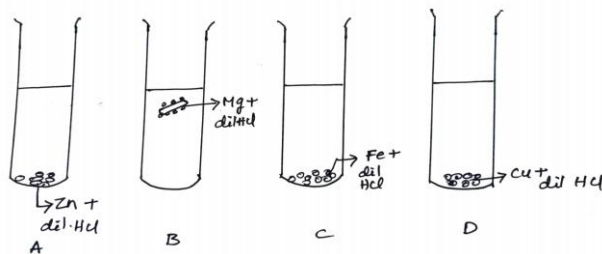

What is the reason for different behaviour of Mg in test tube B?

- Mg is lighter element than dil. HCl
- Mg reacts with dil. HCl to produce H_2 gas which helps in floating
- Mg reacts with dil. HCl to produce N_2 gas which helps in floating
- Mg reacts with dil. HCl to produce CO_2 gas which helps in floating

28.

The table shown below gives information about four substances: A, B, C and D.

SUBSTANCE	MELTING POINT (K)	ELECTRICAL CONDUCTIVITY	
		SOLID	LIQUID/ AQUEOUS
A	295	Good	Good
B	1210	Poor	Good
C	1890	Poor	Good
D	1160	Poor	Poor

Identify Ionic compounds from the above given substances.

- A, B
- B, C
- A, B, D
- A, C, D

29.

Vinay observed that the stain of curry on a white shirt becomes reddish-brown when soap is scrubbed on it, but it turns yellow again when the shirt is washed with plenty of water. What might be the reason for his observation?

- Soap is acidic in nature
 - Soap is basic in nature
 - Turmeric is a natural indicator which gives reddish tinge in bases
 - Turmeric is a natural indicator which gives reddish tinge in acids
- i and ii
 - ii and iii
 - i and iv
 - ii and iv

30.

In which of the following setups would the bulb glow?

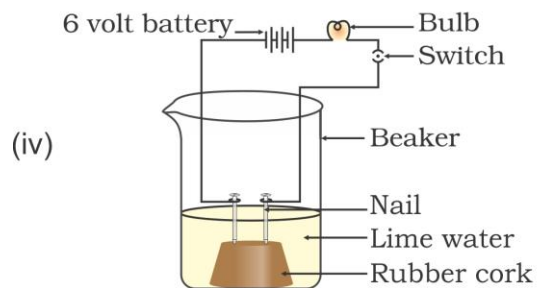
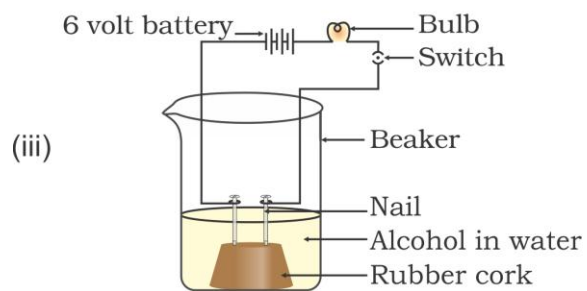
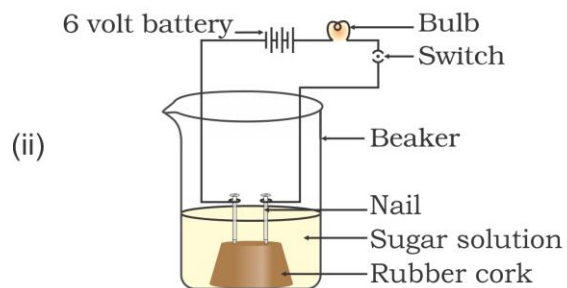
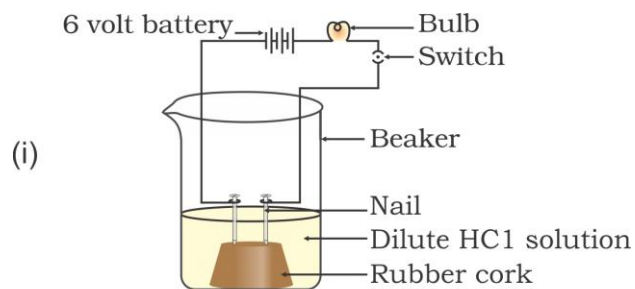

- A. i and ii
- B. i and iv
- C. ii, iii and iv
- D. i, ii and iv

Question No. 31 to 35 consist of two statements – Assertion (A) and Reason (R). Answer these questions selecting the appropriate option given below:

- A. Both A and R are true and R is the correct explanation of A
- B. Both A and R are true and R is not the correct explanation of A
- C. A is true but R is false
- D. A is False but R is true

31.	<p>Assertion: Fresh milk in which baking soda is added, takes a longer time to set as curd.</p> <p>Reason: Baking soda decreases the pH value of fresh milk to below 6.</p>															
32.	<p>Assertion: Decomposition of vegetable matter into compost is an endothermic reaction.</p> <p>Reason: Decomposition reaction involves breakdown of a single reactant into simpler products.</p>															
33.	<p>Assertion: Resins and gums are stored in old xylem tissue in plants.</p> <p>Reason:Resins and gums facilitate transport of water molecules.</p>															
34.	<p>Assertion: Sky appears blue in the day time.</p> <p>Reason: White light is composed of seven colours.</p>															
35.	<p>The table given below shows the reaction of a few elements with acids and bases to evolve Hydrogen gas.</p> <table border="1" style="margin-left: auto; margin-right: auto;"> <thead> <tr> <th style="text-align: center;">Element</th> <th style="text-align: center;">Acid</th> <th style="text-align: center;">Base</th> </tr> </thead> <tbody> <tr> <td style="text-align: center;">A</td> <td style="text-align: center;">x</td> <td style="text-align: center;">x</td> </tr> <tr> <td style="text-align: center;">B</td> <td style="text-align: center;">✓</td> <td style="text-align: center;">✓</td> </tr> <tr> <td style="text-align: center;">C</td> <td style="text-align: center;">✓</td> <td style="text-align: center;">x</td> </tr> <tr> <td style="text-align: center;">D</td> <td style="text-align: center;">✓</td> <td style="text-align: center;">✓</td> </tr> </tbody> </table> <p>Which of these elements form amphoteric oxides?</p> <ul style="list-style-type: none"> A. A and D B. B and D C. A and C D. B and D 	Element	Acid	Base	A	x	x	B	✓	✓	C	✓	x	D	✓	✓
Element	Acid	Base														
A	x	x														
B	✓	✓														
C	✓	x														
D	✓	✓														
36.	<p>In which of the following groups of organisms, blood flows through the heart only once during one cycle of passage through the body?</p> <ul style="list-style-type: none"> A. Rabbit, Parrot, Turtle B. Frog, crocodile, Pigeon C. Whale, Labeo, Penguin D. Shark, dog fish, sting ray 															

37.	<p>What is common between extensive network of blood vessels around walls of alveoli and in glomerulus of nephron?</p> <p>A. Thick walled arteries richly supplied with blood B. Thin walled veins poorly supplied with blood C. Thick walled capillaries poorly supplied with blood. D. Thin walled capillaries richly supplied with blood</p>
38.	<p>Plants use completely different process for excretion as compared to animals. Which one of the following processes is NOT followed by plants for excretion?</p> <p>A. They can get rid of excess water by transpiration. B. They selectively filter toxic substances through their leaves. C. Waste products are stored as resins and gums in old xylem. D. They excrete waste substances into the soil around them.</p>
39.	<p>If the power of a lens is - 4.0 D, then it means that the lens is a</p> <p>A. concave lens of focal length -50 m B. convex lens of focal length +50 cm C. concave lens of focal length -25 cm D. convex lens of focal length -25 m</p>
40.	<p>Rays from Sun converge at a point 15 cm in front of a concave mirror. Where should an object be placed so that size of its image is equal to the size of the object?</p> <p>A. 30 cm in front of the mirror B. 15 cm in front of the mirror C. Between 15 cm and 30 cm in front of the mirror D. More than 30 cm in front of the mirror</p>
41.	<p>In which of the following groups of organisms, food material is broken down outside the body and then absorbed in?</p> <p>A. mushroom, green plants, amoeba B. yeast, mushroom, bread mould C. paramecium, amoeba, cuscuta D. cuscuta, lice, tapeworm</p>
42.	<p>In a person the tubule part of the nephron is not functioning at all. What will its effect be on urine formation?</p> <p>A. The urine will not be formed. B. Quality and quantity of urine is unaffected. C. Urine is more concentrated. D. Urine is more diluted.</p>
43.	<p>If the real image of a candle flame formed by a lens is three times the size of the flame and the distance between lens and image is 80 cm, at what distance should the candle</p>

be placed from the lens?

- A. -80cm
- B. -40 cm
- C. $-40/3$ cm
- D. $-80/3$ cm

44.

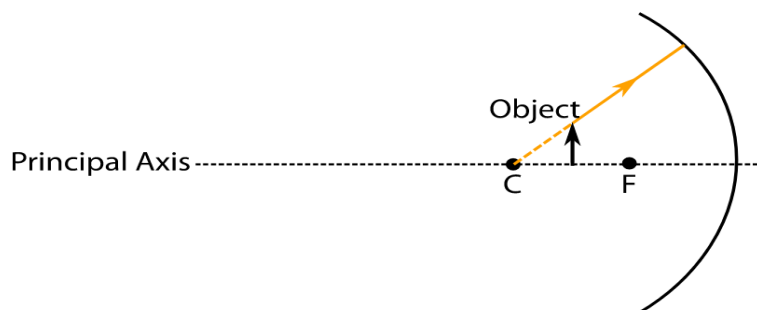

While looking at the above diagram, Nalini concluded the following-

- i. the image of the object will be a virtual one.
- ii. the reflected ray will travel along the same path as the incident ray but in opposite direction.
- iii. the image of the object will be inverted.
- iv. this is a concave mirror and hence the focal length will be negative.

Which one of the above statements are **correct**?

- A. i and ii
- B. i and iii
- C. ii, iii and iv
- D. i, ii, iii and iv

45.

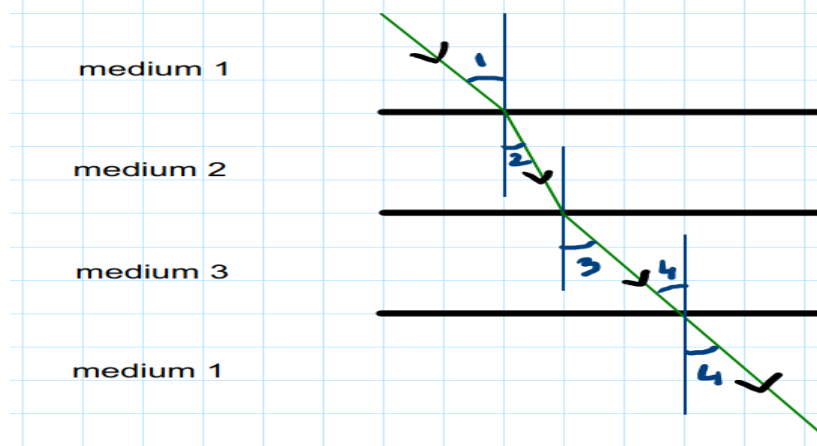

In the above diagram light is travelling through different media. It is noted by a scientist that $\angle 1 = \angle 3 = \angle 4$ but $\angle 2 < \angle 1$. Which of the following statement would be correct?

- A. Medium 1 is the denser than medium 3 but it's density is equal to medium 2.
- B. Medium 2 is the rarest medium.
- C. Medium 3 is denser than medium 1.
- D. Medium 1 and 3 are essentially the same medium, but medium 2 is denser than 1 and 3.

46.

The refractive index of flint glass is 1.65 and that for alcohol is 1.36 with respect to air. What is the refractive index of the flint glass with respect to alcohol ?

- A. 0.82
- B. 1.21
- C. 1.11
- D. 1.01

47.

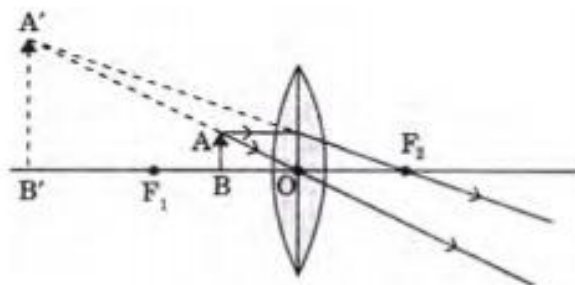

The above lens has a focal length of 10 cm. The object of height 2 mm is placed at a distance of 5 cm from the pole. Find the height of the image.

- A. 4 cm
- B. 6.67 mm
- C. 4 mm
- D. 3.33 mm

48.

A cable manufacturing unit tested few elements on the basis of their physical properties.

Properties	W	X	Y	Z
Malleable	Yes	No	No	Yes
Ductile	Yes	No	No	Yes
Electrical conductivity	Yes	Yes	Yes	No
Melting Point	High	Low	Low	High

Which of the above elements were discarded for usage by the company?

- A. W, X, Y
- B. X, Y, Z
- C. W, X, Z
- D. W, X, Z

SECTION – C

Section- C consists of three Cases followed by questions. There are a total of 12 questions in this section. Attempt any 10 questions from this section.

The first attempted 10 questions would be evaluated.

Case The Salt Story

From: The New Indian Express 9 March 2021

The salt pans in Marakkanam, a port town about 120 km from Chennai are the third largest producer of salt in Tamil Nadu. Separation of salt from water is a laborious process and the salt obtained is used as raw materials for manufacture of various sodium compounds.

One such compound is Sodium hydrogen carbonate, used in baking, as an antacid and in soda acid fire extinguishers.

The table shows the mass of various compounds obtained when 1 litre of sea water is evaporated

COMPOUND	FORMULA	MASS OF SOLID PRESENT /g
Sodium Chloride	NaCl	28.0
Magnesium Chloride	MgCl ₂	8.0
Magnesium Sulphate	MgSO ₄	6.0
Calcium Sulphate	CaSO ₄	2.0
Calcium Carbonate	CaCO ₃	1.0
TOTAL AMOUNT OF SALT OBTAINED		45.0

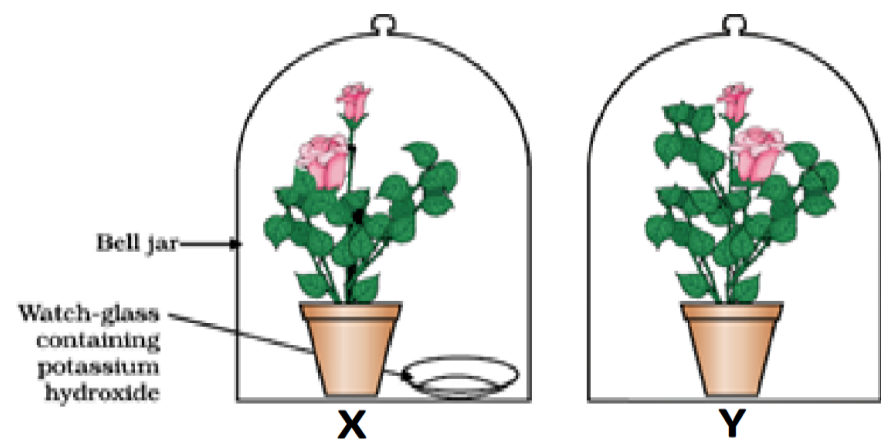
49.	<p>Which compound in the table reacts with acids to release carbon dioxide?</p> <p>A. NaCl B. CaSO₄ C. CaCO₃ D. MgSO₄</p>
50.	<p>How many grams of Magnesium Sulphate are present in 135g of solid left by evaporation of sea water?</p> <p>A. 6g B. 12g C. 18g D. 24g</p>
51.	<p>What is the saturated solution of Sodium Chloride called?</p> <p>A. Brine B. Lime water C. Slaked lime D. Soda water</p>
52.	<p>What is the pH of the acid which is used in the formation of common salt?</p> <p>A. Between 1 to 3 B. Between 6 to 8 C. Between 8 to 10 D. Between 11 to 13</p>
Case	<p>The Figure shown below represents an activity to prove the requirements for photosynthesis. During this activity, two healthy potted plants were kept in the dark for 72 hours. After 72 hours, KOH is kept in the watch glass in setup X and not in setup Y. Both these setups are air tight and have been kept in light for 6 hours. Then, Iodine Test is performed with one leaf from each of the two plants X and Y.</p> 

53.	<p>This experimental set up is used to prove essentiality of which of the following requirements of photosynthesis?</p> <p>A. Chlorophyll B. Oxygen C. Carbon dioxide D. Sunlight</p>
54.	<p>The function of KOH is to absorb</p> <p>A. Oxygen. B. Carbon dioxide. C. Moisture. D. Sunlight.</p>
55.	<p>Which of the following statements shows the correct results of Iodine Test performed on the leaf from plant X and Y respectively?</p> <p>A. Blue - black colour would be obtained on the leaf of plant X and no change in colour on leaf of plant Y. B. Blue - black colour would be obtained on the leaf of plant Y and no change in colour on leaf of plant X. C. Red colour would be obtained on the leaf of plant X and brown colour on the leaf of plant Y. D. Red colour would be obtained on the leaf of plant Y and brown colour on the leaf of plant X.</p>
56.	<p>Which of the following steps can be followed for making the apparatus air tight?</p> <p>i. placing the plants on glass plate ii. using a suction pump. iii. applyingaseline to seal the bottom of jar. iv. creating vacuum</p> <p>A. i and ii B. ii. and iii C. i. and iii D. ii. and iv</p>
Case	<p>Noor, a young student, was trying to demonstrate some properties of light in her Science project work. She kept 'X' inside the box (as shown in the figure) and with the help of a laser pointer made light rays pass through the holes on one side of the box. She had a small butter-paper screen to see the spots of light being cast as they emerged.</p>

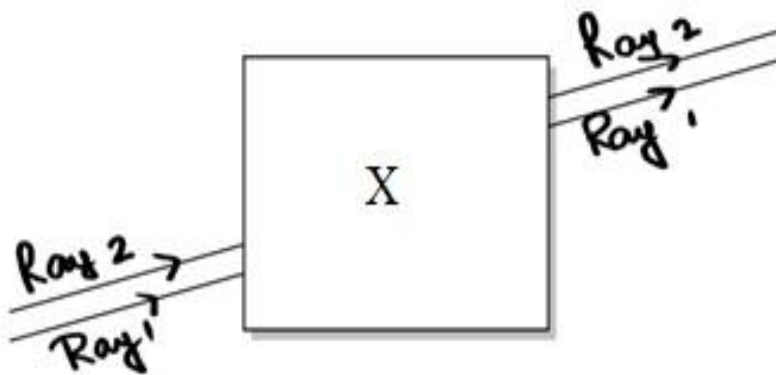

57.

What could be the 'X' that she placed inside the box to make the rays behave as shown?

- A. a converging lens
- B. a parallel-sided glass block
- C. a plane mirror
- D. a triangular prism

58.

She measured the angles of incidence for both the rays on the left side of the box to be 48.6° . She knew the refractive index of the material 'X' inside the box was 1.5. What will be the approximate value of angle of refraction?

- A. 45°
- B. 40°
- C. 30°
- D. 60°

(use the value: $\sin 48.6^\circ \approx 0.75$)

59.

Her friend noted the following observations from this demonstration:

- i. Glass is optically rarer than air.
- ii. Air and glass allow light to pass through them with the same velocity.
- iii. Air is optically rarer than glass.
- iv. Speed of light through a denser medium is faster than that of a rarer medium.
- v. The ratio: sin of angle of incidence in the first medium to the ratio of sin of angle of refraction in the second medium, gives the refractive index of the second material with respect to the first one.

Which one of the combination of the above statements given below is correct.

- A. ii, iv and v are correct.
- B. iii and iv are correct.
- C. i, iv and v are correct.
- D. iii and v are correct.

60	<p>If the object inside the box was made of a material with a refractive index less than 1.5 then the</p> <p>A. lateral shift of the rays would have been less. B. lateral shift of the rays would have been more. C. lateral shift of the rays would remain the same as before. D. there is not enough information to comment on any of the above statements</p>
----	--

Questions in lieu of diagram based questions for VI candidates

Total Alternative Questions – 26

Section – A

2.	<p>A gas is evolved when Dil. Sulphuric Acid reacts with Zinc granules. It gives a pop sound when lit match stick is introduced near it. Identify the gas?</p> <p>A. Nitrogen B. Hydrogen C. Oxygen D. Carbon dioxide</p>
3.	<p><i>Metal X</i> reacts with <i>Dil. HCl</i> to form <i>Metal Salt</i> and <i>Gas</i>. Identify <i>X</i>?</p> <p>A. Copper B. Mercury C. Silver D. Zinc</p>
5.	<p>In the neutralization reaction when excess of acid is added to an alkali, salt and water are produced. What is the nature of the solution after the reaction occurs?</p> <p>A. Amphoteric B. Acidic C. Basic D. Neutral</p>
11	<p>Select the option which gives correct function and /or characteristic: of the four parts of human respiratory system.</p> <p>A. Alveoli: Thin-walled sac like structures for exchange of gases. B. Diaphragm: It is pulled up when we breathe in. C. Trachea: It is supported by bony rings for conducting inspired air. D. Ribs: When we breathe out, ribs are lifted.</p>

12	<p>Identify the option that indicates the correct enzyme that is secreted in location L, M and N.L, M and N represent Mouth cavity, stomach and small intestine of the human being.</p> <table border="1" data-bbox="480 254 1049 485"> <thead> <tr> <th></th> <th>L</th> <th>M</th> <th>N</th> </tr> </thead> <tbody> <tr> <td>A</td> <td>lipase</td> <td>trypsin</td> <td>pepsin</td> </tr> <tr> <td>B</td> <td>amylase</td> <td>pepsin</td> <td>trypsin</td> </tr> <tr> <td>C</td> <td>trypsin</td> <td>amylase</td> <td>lipase</td> </tr> <tr> <td>D</td> <td>lipase</td> <td>amylase</td> <td>pepsin</td> </tr> </tbody> </table>		L	M	N	A	lipase	trypsin	pepsin	B	amylase	pepsin	trypsin	C	trypsin	amylase	lipase	D	lipase	amylase	pepsin
	L	M	N																		
A	lipase	trypsin	pepsin																		
B	amylase	pepsin	trypsin																		
C	trypsin	amylase	lipase																		
D	lipase	amylase	pepsin																		
14	<p>Given below are the functions of some parts of human circulatory system. Identify the correct match.</p> <p>A. Pulmonary vein – takes oxygenated blood from body parts to heart B. Artery – takes oxygenated blood from heart to lung C. Dorsal aorta – takes deoxygenated blood from heart to body parts D. Vena cava – takes deoxygenated blood from body parts to right atrium</p>																				
15	<p>What happens when right and left ventricle contract during pumping of blood by human heart?</p> <p>A. Blood transferred to the right ventricle and left ventricle simultaneously. B. Blood is transferred to lungs for oxygenation and is pumped into various organs simultaneously. C. Blood transferred to the right atrium and left atrium simultaneously. D. Blood is received from lungs after oxygenation and is received from various organs of the body.</p>																				
16	<p>i, ii, iii and iv represent mouth cavity, liver, first part of small intestine and complete small intestine respectively of Human digestive system. Match the labeling referred in column I and correlate with the function in column II.</p> <table border="1" data-bbox="331 1209 1360 1472"> <thead> <tr> <th>Column I</th> <th>Column II</th> </tr> </thead> <tbody> <tr> <td>i</td> <td>a. The length of this depends of food the organism eats.</td> </tr> <tr> <td>ii</td> <td>b. Initial phase of starch digestion.</td> </tr> <tr> <td>iii</td> <td>c. Increase the efficiency of lipase enzyme action.</td> </tr> <tr> <td>iv</td> <td>d. This is the site of the complete digestion of carbohydrates, proteins and fats.</td> </tr> </tbody> </table> <p>A. i.- c ; ii – d ; iii – a ; iv- d B. i.- b ; ii – c ; iii – d ; iv- a C. i.- a ; ii – c ; iii – d ; iv- c D. i.- d ; ii – a ; iii – b ; iv- c</p>	Column I	Column II	i	a. The length of this depends of food the organism eats.	ii	b. Initial phase of starch digestion.	iii	c. Increase the efficiency of lipase enzyme action.	iv	d. This is the site of the complete digestion of carbohydrates, proteins and fats.										
Column I	Column II																				
i	a. The length of this depends of food the organism eats.																				
ii	b. Initial phase of starch digestion.																				
iii	c. Increase the efficiency of lipase enzyme action.																				
iv	d. This is the site of the complete digestion of carbohydrates, proteins and fats.																				
18	<p>If a virtual, erect and enlarged image is formed by a lens, then which of the following options are correct?</p> <p>A. It is a concave lens and the object is placed between pole and focus. B. It is a convex lens and the object is placed between focus and centre of curvature. C. It is a convex lens and the object is placed between pole and focus. D. It is a concave lens and the object is placed between focus and centre of curvature.</p>																				

22	<p>Consider the situation where:</p> <ul style="list-style-type: none"> • An object is 3 cm (height) • Mirror is concave with 6 cm focal length. • Object is placed at the centre of curvature. <p>Which of the following options are correct?</p> <p>A. The mirror will produce an image of magnification +1.5. B. The mirror will produce an image of magnification -1. C. The mirror will produce an image of magnification +1. D. The mirror will produce an image of magnification -1.5.</p>
23	<p>If a ray passes from air to glass in a spherical glass slab and passes through the centre of the slab without deviation, then the angle of incidence from air to glass at the point on the glass slab is.</p> <p>A. 45° B. 0° C. 90° D. 180°</p>
24	<p>Out of all colours making the white light, which one will deviate the most while it passes through a prism?</p> <p>A. Red. B. Violet. C. Blue. D. Green.</p>
Section - B	
26.	<p><i>Even though rain water is the purest form of water, it acts as an electrolyte. However, distilled water cannot be an electrolyte.</i></p> <p>The reason for this is</p> <p>A. rain water consists of dissolved oxygen B. rain water consists of dissolved oxides of sulphur C. rain water consists of dissolved Nitrogen D. rain water consists of dissolved oxides of Hydrogen</p>
27.	<p>The reason for different behaviour (floating) of Mg in dil HCl is due to:</p> <p>A. Mg is lighter element than dil. HCl B. Mg reacts with dil. HCl to produce H₂ gas which helps in floating C. Mg reacts with dil. HCl to produce N₂ gas which helps in floating D. Mg reacts with dil. HCl to produce CO₂ gas which helps in floating</p>
30.	<p>Which of the following solutions are electrolytes?</p> <p>i. Dil. HCl ii. Sugar Solution iii. Alcohol in water iv. Lime water</p>

	<p>A. i and ii B. i and iv C. ii, iii and iv D. i, ii and iv</p>
44.	<p>Nalinl draws a ray diagram for an object in front of a concave mirror. She draws a ray starting from the top of the object and falling on the mirror perpendicularly. The ray after reflection will</p> <p>A. pass through focus. B. pass through pole. C. pass through the centre of curvature. D. pass through any point on the principal axis.</p>
45.	<p>If the refractive index of water with respect to air is 1.33 and of that of glass with respect to air is 1.5 then</p> <p>A. water is optically denser than glass. B. air is optically densest of all the three media. C. air's optical density is between glass and air. D. glass is optically denser than water.</p>
47.	<p>A convex lens has a focal length of 10 cm. The object of height 2 mm is placed at a distance of 5 cm from the pole. Find the height of the image.</p> <p>A. 4 cm B. 6.67 mm C. 4 mm D. 3.33 mm</p>
Section - C	
Case	<p>A student was performing an activity to prove the requirements for photosynthesis. During this activity, he kept two identical healthy potted plants A and B in dark for 72 hours. After 72 hours, he covered plant A and B by bell shaped jars separately. While covering the plants with separate bell jars, he kept KOH in the watch glass by the side of the plant in setup A and not in setup B. Both these setups were made air tight and were kept in light for 6 hours. Then, Iodine Test was performed with one leaf from each of the two plants A and B.</p>
53.	<p>This experimental set up is used to prove essentiality of which of the following requirements of photosynthesis?</p> <p>A. Chlorophyll B. Oxygen C. Carbon dioxide D. Sunlight</p>
54.	<p>The function of KOH is to absorb</p> <p>A. Oxygen. B. Carbon dioxide. C. Moisture. D. Sunlight.</p>

55.	<p>Which of the following statements shows the correct results of Iodine Test performed on the leaf from plant A and B respectively?</p> <p>A. Blue - black colour would be obtained on the leaf of plant A B. Blue - black colour would be obtained on the leaf of plant B C. Red colour would be obtained on the leaf of plant A D. Red colour would be obtained on the leaf of plant B</p>
56.	<p>Which of the following steps can be followed for making the apparatus air tight?</p> <p>i. placing the plants on glass plate ii. using a suction pump. iii. applying Vaseline to seal the bottom of jar. iv. creating vacuum</p> <p>A. i and ii B. ii. and iii C. i. and iii D. ii. And iv</p>
Case	<p>In an experiment, Pooja used a equilateral triangular glass prism and projected a narrow beam of white light source from one side of the surface of the prism. She placed a screen on the other side and saw many colours appearing as patches on the screen. But when she used a red light source, she could only see a red patch on the screen. Similarly she used a blue and green light source and could only see one colour patch on both occasions.</p>
57.	<p>The phenomenon that she was trying to demonstrate was:</p> <p>A. Dispersion B. Reflection C. Refraction D. Scattering.</p>
58.	<p>The reason why she could no see any other colour when the red light was used was because:</p> <p>A. Red colour does not refract in prism. B. Red colour is monochromatic. C. The prism was defective. D. The prism is opaque to red colour.</p>
59.	<p>Which of the following can be the correct explanation that Pooja can give to her friends to explain this phenomenon?</p> <p>A. Different lights travel faster in the glass prism at different rates. B. Any light would disperse in the prism. C. Enough data is not available to make a scientific explanation in this case. D. Different wavelengths travel at different speeds in the glass.</p>
60.	<p>She also could relate to another natural phenomenon that we observe on a rainy humid day as the sun comes out. What could be that phenomenon?</p> <p>A. Lightning. B. Blueness of the sky. C. Rainbow. D. Scattering of light.</p>

SAMPLE QUESTION PAPER

CLASS X

Science (086)

Term 2 (2021-22)

Max. Marks:40

Time allowed: 2 hours

General Instructions:

- i) All questions are compulsory.
- ii) The question paper has **three sections** and **15 questions**. All questions are compulsory.
- iii) Section–A has 7 questions of 2 marks each; Section–B has 6 questions of 3 marks each; and Section–C has 2 case based questions of 4 marks each.
- iv) Internal choices have been provided in some questions. A student has to attempt only one of the alternatives in such questions.

SECTION - A

1	<p>The table shows the electronic structures of four elements.</p> <table border="1" style="margin: 10px auto; border-collapse: collapse;"><thead><tr><th style="padding: 5px;">Element</th><th style="padding: 5px;">Electronic Structure</th></tr></thead><tbody><tr><td style="text-align: center; padding: 5px;">P</td><td style="text-align: center; padding: 5px;">2,6</td></tr><tr><td style="text-align: center; padding: 5px;">Q</td><td style="text-align: center; padding: 5px;">2,8,1</td></tr><tr><td style="text-align: center; padding: 5px;">R</td><td style="text-align: center; padding: 5px;">2,8,7</td></tr><tr><td style="text-align: center; padding: 5px;">S</td><td style="text-align: center; padding: 5px;">2,8,8</td></tr></tbody></table> <p>a. Identify which element(s) will form covalent bonds with carbon.</p> <p>b. “Carbon reacts with an element in the above table to form several compounds.” Give suitable reason.</p>	Element	Electronic Structure	P	2,6	Q	2,8,1	R	2,8,7	S	2,8,8	2
Element	Electronic Structure											
P	2,6											
Q	2,8,1											
R	2,8,7											
S	2,8,8											
2	<p>The diagram below shows part of the periodic table.</p> <p>a. Which elements would react together to form covalent compounds?</p> <p>b. Between the two elements W and Z, which will have a bigger atomic radius? Why?</p> <div style="text-align: center; margin: 10px 0;"><pre>graph TD subgraph PeriodicTable [Periodic Table] direction TB subgraph sBlock [s-block] S1[] S2[] S3[] S4[] end subgraph dBlock [d-block] D1[] D2[] D3[] D4[] D5[] D6[] D7[] D8[] D9[] D10[] D11[] D12[] W[W] end subgraph pBlock [p-block] P1[] P2[] P3[] P4[] P5[] P6[] P7[] Y[Y] Z[Z] end end</pre></div>	2										
3	<p>a. Trace the path a male gamete takes to fertilise a female gamete after being released from the penis.</p> <p>b. State the number of sets of chromosomes present in a zygote.</p>	2										

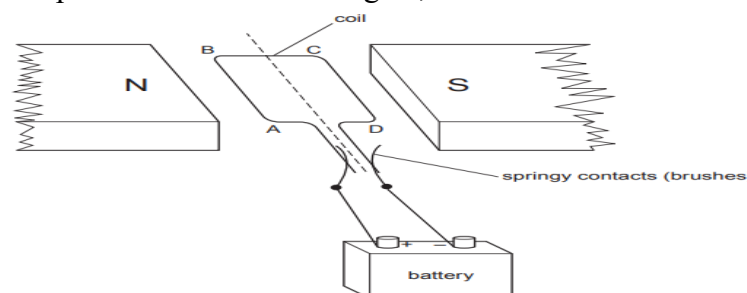
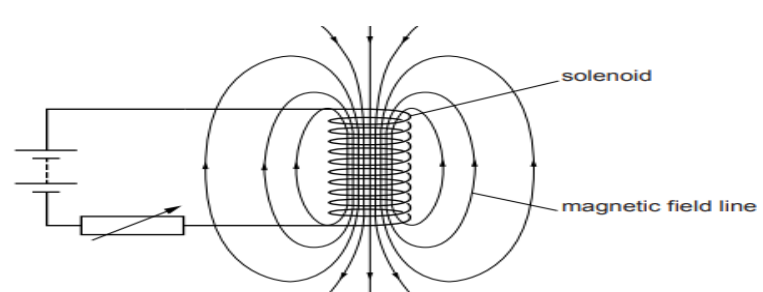
4	<p>Rajesh observed a patch of greenish black powdery mass on a stale piece of bread.</p> <p>a. Name the organism responsible for this and its specific mode of asexual reproduction.</p> <p>b. Name its vegetative and reproductive parts.</p>	2
5	<p>Mustard was growing in two fields- A and B. While Field A produced brown coloured seeds, field B produced yellow coloured seeds.</p> <p>It was observed that in field A, the offsprings showed only the parental trait for consecutive generations, whereas in field B, majority of the offsprings showed a variation in the progeny.</p> <p>What are the probable reasons for these?</p> <p>OR</p> <p>In an asexually reproducing species, if a trait X exists in 5% of a population and trait Y exists in 70% of the same population, which of the two trait is likely to have arisen earlier? Give reason.</p>	2
6	<p>A simple motor is made in a school laboratory. A coil of wire is mounted on an axle between the poles of a horseshoe magnet, as illustrated.</p>  <p>In the example above, coil ABCD is horizontal and the battery is connected as shown.</p> <p>a. For this position, state the direction of the force on the arm AB.</p> <p>b. Why does the current in the arm BC not contribute to the turning force on the coil?</p> <p>OR</p> <p>A circuit contains a battery, a variable resistor and a solenoid. The figure below shows the magnetic field pattern produced by the current in the solenoid.</p>  <p>a. State how the magnetic field pattern indicates regions where the magnetic field is stronger.</p>	2

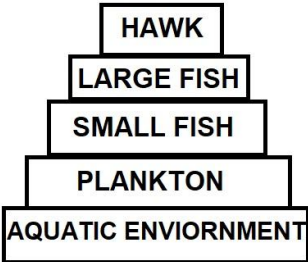
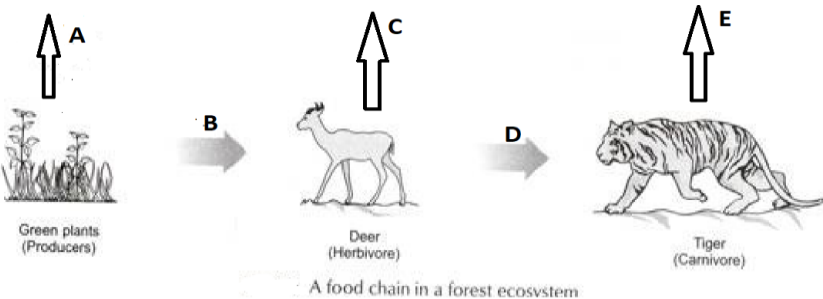
	b. What happens to the magnetic field when the current in the circuit is reversed?	
7	<p>DDT was sprayed in a lake to regulate breeding of mosquitoes. How would it affect the trophic levels in the following food chain associated with a lake? Justify your answer.</p> <div style="text-align: center;">  </div> <p>OR</p> <p>In the following food chain, vertical arrows indicate the energy lost to the environment and horizontal arrows indicate energy transferred to the next trophic level. Which one of the three vertical arrows (A, C and E) and which one of the two horizontal arrows (B and D) will represent more energy transfer? Give reason for your answer.</p> <div style="text-align: center;">  </div>	2
SECTION - B		
8	<p>Choose an element from period 3 of modern periodic table that matches the description given below in each instance. Give reason for your choice.</p> <ol style="list-style-type: none"> It has a similar structure to diamond. It has same valency as Lithium. It has variable valency and is a member of the Oxygen family (group 16). 	3
9	<ol style="list-style-type: none"> How many isomers are possible for the compound with the molecular formula C_4H_8? Draw the electron dot structure of branched chain isomer. How will you prove that C_4H_8 and C_5H_{10} are homologues? <p>OR</p> <p>A carbon compound 'A' having melting point 156K and boiling point 351K, with molecular formula C_2H_6O is soluble in water in all proportions.</p> <ol style="list-style-type: none"> Identify 'A' and draw its electron dot structure. Give the molecular formulae of any two homologues of 'A'. 	3

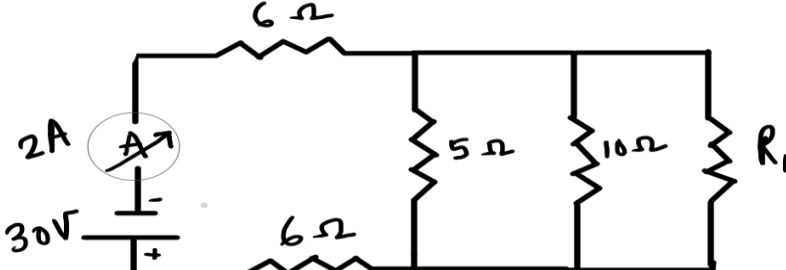
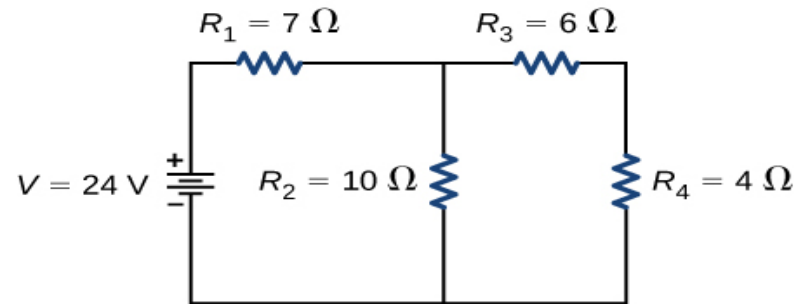
10	<p>Two pea plants - one with round yellow seeds (RRYY) and another with wrinkled green (rryy) seeds produce F1 progeny that have round, yellow (RrYy) seeds.</p> <p>When F1 plants are self-pollinated, which new combination of characters is expected in F2 progeny? How many seeds with these new combinations of characters will be produced when a total 160 seeds are produced in F2 generation? Explain with reason.</p>	3
11	<p>a. It would cost a man Rs. 3.50 to buy 1.0 kW h of electrical energy from the Main Electricity Board. His generator has a maximum power of 2.0 kW. The generator produces energy at this maximum power for 3 hours. Calculate how much it would cost to buy the same amount of energy from the Main Electricity Board.(1 Mark)</p> <p>b. A student boils water in an electric kettle for 20 minutes. Using the same mains supply he wants to reduce the boiling time of water. To do so should he increase or decrease the length of the heating element? Justify your answer.(2 Marks)</p>	3
12	<div style="text-align: center;">  </div> <p>In the above circuit, if the current reading in the ammeter A is 2A, what would be the value of R_1?</p> <p>OR</p> <div style="text-align: center;">  </div> <p>Calculate the total resistance of the circuit and find the total current in the circuit.</p>	3
13	<p>Gas A, found in the upper layers of the atmosphere, is a deadly poison but is essential for all living beings. The amount of this gas started declining sharply in the 1980s.</p> <p>a. Identify Gas A. How is it formed at higher levels of the atmosphere?</p> <p>b. Why is it essential for all living beings? State the cause for the depletion of this gas.</p>	3

SECTION – C

This section has 02 case-based questions (14 and 15). Each case is followed by 03 sub-questions (a, b and c). Parts a and b are compulsory. However, an internal choice has been provided in part c.

14	<p>Sahil performed an experiment to study the inheritance pattern of genes. He crossed tall pea plants (TT) with short pea plants (tt) and obtained all tall plants in F1 generation.</p> <p>a. What will be set of genes present in the F1 generation? (1 Mark)</p> <p>b. Give reason why only tall plants are observed in F1 progeny. (1 Mark)</p> <p>c. When F1 plants were self - pollinated, a total of 800 plants were produced. How many of these would be tall, medium height or short plants? Give the genotype of F 2 generation. (2 Marks)</p> <p>OR</p> <p>When F1 plants were cross - pollinated with plants having tt genes, a total of 800 plants were produced. How many of these would be tall, medium height or short plants? Give the genotype of F 2 generation.</p>	4
15	<p>Ansari Sir was demonstrating an experiment in his class with the setup as shown in the figure below.</p> <div data-bbox="459 965 1023 1294" data-label="Diagram"><p>The diagram illustrates an experiment setup. A horizontal bar is attached to a ceiling. A spring is suspended from the bar. A cylindrical magnet is attached to the bottom of the spring. The magnet has a North (N) pole at the top and a South (S) pole at the bottom. The magnet is positioned above a stationary coil. The coil is connected to a galvanometer, which is represented by a circle with an upward-pointing arrow. Labels with leader lines identify the 'spring', 'moving magnet', 'stationary coil', and 'galvanometer'.</p></div> <p>A magnet is attached to a spring. The magnet can go in and out of the stationary coil.</p> <p>He lifted the Magnet and released it to make it oscillate through the coil. Based on your understanding of the phenomenon, answer the following questions.</p> <p>a. What is the principle which Ansari Sir is trying to demonstrate?</p> <p>b. What will be observed when the Magnet starts oscillating through the coil. Explain the reason behind this observation.</p> <p>c. Consider the situation where the Magnet goes in and out of the coil. State two changes which could be made to increase the deflection in the galvanometer.</p> <p>OR</p> <p>Is there any difference in the observations in the galvanometer when the Magnet swings in and then out of the stationary coil? Justify your answer.</p>	4
