

MATHEMATICS

1. If $f(x) = \begin{cases} x-2 & 0 \leq x \leq 2 \\ -2 & -2 \leq x \leq 0 \end{cases}$ and $h(x) = f(|x|) + |f(x)|$ then $\int_0^k h(x) dx$ is equal to ($k > 0$)
- (1) 0 (2) $\frac{k}{2}$ (3) 2k (4) k

Ans. (1)

Sol. $f(|x|) = \begin{cases} -2-x, & x < 0 \\ x-2, & x > 0 \end{cases}$ | $f(x) = \begin{cases} 2, & x < 0 \\ 2-x, & x > 0 \end{cases}$

$\Rightarrow h(x) = f(|x|) + |f(x)| = \begin{cases} -x, & x < 0 \\ 0, & x > 0 \end{cases}$

$\Rightarrow \int_0^k h(x) dx = \int_0^k 0 dx = 0$

2. There are three bags A, B and C. Bag A contain 7 Black balls and 5 Red balls, Bag B contains 5 Red and 7 Black balls and Bag C contain 7 Red and 7 Black balls. A ball is drawn and found to be black find probability that it is drawn from Bag A.

Ans. $\left(\frac{7}{18}\right)$

Sol.
$$\text{Prob} = \frac{\frac{7}{12}}{\frac{7}{12} + \frac{5}{12} + \frac{7}{14}}$$

$$= \frac{\frac{7}{6}}{\frac{7}{6} + \frac{5}{6} + 1}$$

$$= \frac{7}{7+5+6} = \frac{7}{18}$$

3. Find the number of rational numbers in the expansion of $\left(2^{\frac{1}{5}} + 5^{\frac{1}{3}}\right)^{15}$.

Ans. (2)

Sol. $T_{r+1} = {}^{15}C_r \left(2^{1/5}\right)^{15-r} \left(5^{1/3}\right)^r$

$= {}^{15}C_r 2^{3-\frac{r}{5}} \cdot 5^{\frac{r}{3}}; r = 3K \& 5K$

There $r = 0; 15$

So Total No. of Rational Terms are "2".

4. Find value of $\int_0^{\frac{\pi}{2}} \frac{\sin^2 x}{1 + \sin x \cos x} dx$

Ans. $(\frac{\pi}{3\sqrt{3}})$

Sol. $\Rightarrow I = \int_0^{\pi/2} \frac{\cos^2 x dx}{1 + \sin x \cos x}$

$$\therefore 2I = \int_0^{\pi/2} \frac{2 dx}{2 + \sin 2x}$$

$$I = \int_0^{\pi/2} \frac{dx}{2 + \frac{2 \tan x}{1 + \tan^2 x}}$$

$$2I = \int_0^{\pi/2} \frac{\sec^2 x dx}{\tan^2 x + \tan x + 1}$$

$$2I = \int_0^{\infty} \frac{dt}{t^2 + t + 1}$$

$$2I = \int_0^{\infty} \frac{dt}{\left(t + \frac{1}{2}\right)^2 + \left(\frac{\sqrt{3}}{2}\right)^2}$$

$$2I = \frac{1}{\sqrt{3}/2} \left[\tan^{-1} \left(\frac{t + \frac{1}{2}}{\sqrt{3}/2} \right) \right]_0^{\infty}$$

$$I = \frac{1}{\sqrt{3}} \left[\frac{\pi}{2} - \frac{\pi}{6} \right]$$

$$I = \frac{\pi}{3\sqrt{3}}$$

5. If $x^2 - ax + b = 0$ has roots 2, 6; and $\alpha = \frac{1}{2a+1}$; $\beta = \frac{1}{2b-a}$. Find equation having roots α, β .

Ans. $(272x^2 - 33x + 1 = 0)$

Sol. $a = 2 + 6 = 8$

$$b = 2 \times 6 = 12$$

$$\alpha = \frac{1}{17}; \beta = \frac{1}{16}$$

$$\text{Required EQ}^n = x^2 - \left(\frac{1}{17} + \frac{1}{16}\right)x + \frac{1}{17} \times \frac{1}{16}$$

$$\Rightarrow 272x^2 - 33x + 1 = 0$$

6. $\lim_{x \rightarrow 4} \frac{(5+x)^{\frac{1}{3}} - (1+2x)^{\frac{1}{3}}}{(5+x)^{\frac{1}{2}} - (1+2x)^{\frac{1}{2}}}$

Ans. $(\frac{2 \times 9^{1/3}}{9})$

Sol. $\lim_{x \rightarrow 4} \frac{(5+x)^{1/3} - (1+2x)^{1/3}}{(5+x)^{1/2} - (1+2x)^{1/2}}$

$$\frac{(9+h)^{1/3} - (9+2h)^{1/3}}{(9+h)^{1/2} - (9+2h)^{1/2}} = \frac{9^{1/3} \left[\frac{h}{27} - \frac{2h}{27} \right]}{3 \left(\frac{h}{18} - \frac{h}{9} \right)}$$

$$= \frac{9^{1/3} \left(\frac{-h}{27} \right)}{3 \frac{-h}{18}}$$

$$= \frac{2 \times 9^{1/3}}{9}$$

7. AB, BC, CA are sides of triangle having 5, 6, 7 points respectively. How many triangles are possible using these points.

Ans. (751)

Sol. ${}^{18}C_3 - {}^5C_3 - {}^6C_3 - {}^7C_3$

$$= 17 \times 16 \times 3 - 10 - 20 - 35$$

$$= 816 - 65 = 751$$

8. 2, p and q are in G.P. in an A.P. 2 is third term, p is 7th term and q is 8th term find p and q.

Ans. $(P = \frac{1}{2}, q = \frac{1}{8})$

Sol. $p = 2r, q = 2r^2$

In A.P. $A + 2d = 2$
 $A + 6d = 2r$
 $A + 7d = 2r^2$

By Solving $r = \frac{1}{4}$

$P = \frac{1}{2}, q = \frac{1}{8}$

9. If the domain of the function $\sin^{-1} \left(\frac{3x-22}{2x-19} \right) + \log_e \left(\frac{3x^2-8x+5}{x^2-3x-10} \right)$ is $[\alpha, \beta]$ then $3\alpha + 10\beta$ is equal to

- (1) 100 (2) 95 (3) 97 (4) 98

Ans. (3)

Sol. $-1 \leq \frac{3x-22}{2x-19} \leq 1$

$$\frac{3x-22}{2x-19} + 1 \geq 0$$

$$\frac{5x-41}{2x-19} \geq 0 \Rightarrow x \in \left(-\infty, \frac{41}{5} \right] \cup \left[\frac{19}{2}, \infty \right)$$

$$\frac{3x-22}{2x-19} - 1 \leq 0$$

$$\frac{x-3}{2x-19} \leq 0 \Rightarrow x \in \left[3, \frac{19}{2} \right)$$

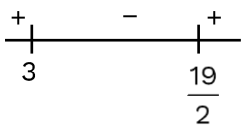

$$\frac{3x^2 - 3x - 5x + 5}{x^2 - 5x + 2x - 10} > 0$$

$$\frac{(3x-5)(x-1)}{(x-5)(x+2)} > 0$$

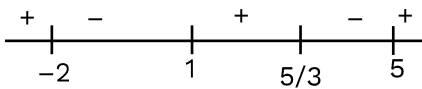

$$\Rightarrow \left[5, \frac{41}{5} \right)$$

$$= 3 \times 5 + 10 \times \frac{41}{5}$$

$$= 15 + 82 = 97$$

10. $x + (2\sin 2\theta)y + 2\cos 2\theta = 0$

$$x + (\sin \theta)y + \cos \theta = 0$$

$$x + (\cos \theta)y - \sin \theta = 0$$

find nontrivial solution

Ans. $\left(\alpha = \cos^{-1} \left(\frac{1}{2\sqrt{2}} \right) \right)$

Sol. $\begin{vmatrix} 1 & 2\sin 2\theta & 2\cos 2\theta \\ 1 & \sin \theta & \cos \theta \\ 1 & \cos \theta & -\sin \theta \end{vmatrix} = 0$

$$1[-\sin^2 \theta - \cos^2 \theta] - 2\sin 2\theta[-\sin \theta - \cos \theta] + 2\cos 2\theta[\cos \theta - \sin \theta] = 0$$

$$-1 + 2\sin 2\theta(\sin \theta + \cos \theta) + 2\cos 2\theta[\cos \theta - \sin \theta] = 0$$

$$-1 + 2\sin \theta \sin 2\theta + 2\sin 2\theta \cos \theta + 2\cos \theta \cos 2\theta - 2\cos 2\theta \sin \theta = 0$$

$$-1 + 2\cos \theta + 2\sin \theta = 0$$

$$\sin \theta + \cos \theta = \frac{1}{2}$$

$$\frac{1}{\sqrt{2}} \sin \theta + \frac{1}{\sqrt{2}} \cos \theta = \frac{1}{2\sqrt{2}}$$

$$\cos \left(\theta - \frac{\pi}{4} \right) = \cos \alpha$$

$$\theta - \frac{\pi}{4} = 2n\pi \pm \alpha$$

where $\alpha = \cos^{-1} \left(\frac{1}{2\sqrt{2}} \right)$

11. Let $f(x) = x^5 + 2e^{x/4}$ for all $x \in \mathbb{R}$. consider a function $(g \circ f)(x) = x$ for all $x \in \mathbb{R}$. Then the value of $8g'(2)$ is

- (1) 4 (2) 16 (3) 8 (4) 2

Ans. (2)

Sol. $g(f(x)) = x$

$$g'(f(x)) \cdot f'(x) = 1$$

$$g'(f(x)) = \frac{1}{f'(x)} \quad ; \quad f'(x) = 5x^4 + \frac{1}{2}e^{x/4}$$

$$g'(2) = \frac{1}{f'(0)} = \frac{1}{2/4} = 2 \quad f'(0) = \frac{1}{2}$$

$$8g'(2) = 16$$

12. Let $f(x) = \frac{2x^2 - 3x + 9}{2x^2 + 3x + 4}$. If maximum value of $f(x)$ is m and minimum value of $f(x)$ is n then

find

$m + n$?

Ans. (10)

Sol. $y = \frac{2x^2 - 3x + 9}{2x^2 + 3x + 4}$

$$y(2x^2 + 3x + 4) = 2x^2 - 3x + 9$$

$$(y - 1)2x^2 + 3x(y + 1) + 4y - 9 = 0$$

$$\text{If } y \neq 1 \Rightarrow D \geq 0$$

$$9(y + 1)^2 - 4(y - 1)(4y - 9) \geq 0$$

$$9(y^2 + 2y + 1) - 4(4y^2 - 9y - 4y + 9) \geq 0$$

$$9y^2 - 16y^2 + 18y + 52y + 9 - 36 \geq 0$$

$$-7y^2 + 70y - 27 \geq 0$$

$$7y^2 - 70y + 27 \leq 0 \quad \text{has roots } \alpha \text{ and } \beta \quad y = \frac{70 \pm \sqrt{4900 - 4 \times 7 \times 27}}{2 \times 7}$$

$$\Rightarrow \alpha \leq y \leq \beta \quad y = \frac{70 \pm \sqrt{4144}}{14}$$

$$\alpha = m = \frac{70 - \sqrt{4144}}{14}$$

$$\beta = n = \frac{70 + \sqrt{4144}}{14}$$

$$= m + n = 10$$

13. $f(x) = \begin{cases} \frac{1 - \cos 2x}{x^2} & x < 0 \\ \alpha & x = 0 \\ \beta \frac{\sqrt{1 - \cos x}}{x} & x > 0 \end{cases}$. If $f(x)$ is continuous at $x = 0$ find $\alpha^2 + \beta^2$.

Ans. (12)

Sol. $\lim_{x \rightarrow 0} \frac{1 - \cos 2x}{x^2} = 2 = \alpha = \lim_{x \rightarrow 0} \beta \sqrt{\frac{1 - \cos x}{x^2}} = \frac{\beta}{\sqrt{2}}$.

Hence $\alpha^2 + \beta^2 = 4 + 8 = 12$

14. Let α and β be the sum and the product of all the nonzero solutions of the equation $(\bar{z})^2 + |z| = 0, z \in \mathbb{C}$ then $4(\alpha^2 + \beta^2)$ is equal to

- (1) 6 (2) 2 (3) 4 (4) 8

Ans. (4)

Sol. $\bar{z}^2 + |z| = 0$

$x^2 - y^2 - 2xyi + \sqrt{x^2 + y^2} = 0$

$x = 0$

$y^2 = \sqrt{y^2}$

$y^2 = |y| \qquad y = 1, -1$

$i, -i$

$y = 0$

$x^2 + \sqrt{x^2 + y^2} = 0 \qquad \text{No non zero solution}$

$\alpha = 0 \qquad \beta = 1$

$4(\alpha^2 + \beta^2) = 4$

15. A square is inscribed in the circle $x^2 + y^2 - 10x - 6y + 30 = 0$. One side of this square is parallel to $y = x + 3$. If (x_i, y_i) are the vertices of the square, then $\sum(x_i^2 + y_i^2)$ is equal to:

- (1) 148 (2) 156 (3) 152 (4) 160

Ans. (3)

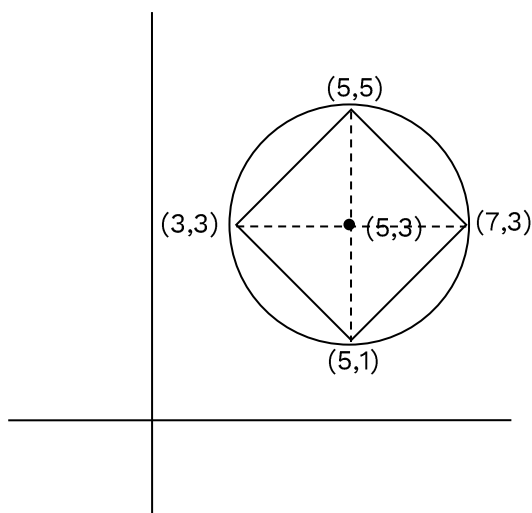

Sol.

$\sum x_i^2 + y_i^2 = 25 + 25 + 49 + 9 + 25 + 1 + 9 + 9 = 152$

16. If differential equation satisfies $\frac{dy}{dx} - y = \cos x$ at $x = 0, y = \frac{-1}{2}$. Find $y\left(\frac{\pi}{4}\right)$.

Ans. (0)

Sol. $\frac{dy}{dx} - y = \cos x$

$$I \cdot f = e^{\int -1 dx} = e^{-x}$$

$$y \cdot e^{-x} = \int e^{-x} \cdot \cos x dx$$

$$I = \int e^{-x} \cos x dx$$

$$I = (-e^{-x}) \cos x - \int (-\sin x)(-e^{-x}) dx$$

$$I = -e^{-x} \cos x - \int e^{-x} \sin x dx$$

$$I = -e^{-x} \cos x - \left[(-e^{-x}) \sin x + \int e^{-x} \cos x dx \right]$$

$$I = -e^{-x} \cos x + e^{-x} \sin x - I$$

$$2I = e^{-x}(\sin x - \cos x)$$

$$y \cdot e^{-x} = \frac{e^{-x}(\sin x - \cos x)}{2} + c$$

$$y = \frac{(\sin x - \cos x)}{2} + c$$

$$c = 0$$

$$y\left(\frac{\pi}{4}\right) = \frac{\frac{1}{\sqrt{2}} - \frac{1}{\sqrt{2}}}{2} = 0$$

17. Let $\alpha, \beta, \in \mathbb{R}$. Let the mean and the variance of 6 observations $-3, 4, 7, -6, \alpha, \beta$ be 2 and 23 respectively. The mean deviation about the mean of these 6 observations is

(1) $\frac{11}{3}$

(2) $\frac{16}{3}$

(3) $\frac{13}{3}$

(4) $\frac{14}{3}$

Ans. (3)

Sol. $\bar{x} = 2 = \frac{-3+4+7-6+\alpha+\beta}{6} \Rightarrow \alpha+\beta = 10$

$$\sigma^2 = 23 = \frac{(-3-2)^2 + (4-2)^2 + (7-2)^2 + (-6-2)^2 + (\alpha-2)^2 + (\beta-2)^2}{6}$$

$$\Rightarrow \alpha^2 + \beta^2 = 52$$

$$\therefore \alpha = 6 \text{ \& } \beta = 4$$

$$\therefore \text{M. D. about mean} = \frac{13}{3}$$

18. $\vec{a} = 2\hat{i} + 2\hat{j} - \hat{k}$ and $\vec{b} = \hat{i} - \hat{k}$, \vec{c} is an unit vector making angle 60° with \vec{a} and 45° with \vec{b} . Find \vec{c}

Ans. (1)

Sol. Let $\vec{c} = C_1\hat{i} + C_2\hat{j} + C_3\hat{k}$, where $2C_1 + 2C_2 - C_3 = \frac{3}{2}$

$$C_1 - C_2 = 1$$

$$C_1^2 + C_2^2 + C_3^2 = 1.$$

19. If the length of focal chord of $y^2 = 12x$ is 15 and if the distance of the focal chord from origin is p then $10p^2$ is equal to

- (1) 36 (2) 25 (3) 72 (4) 144

Ans. (3)

Sol.

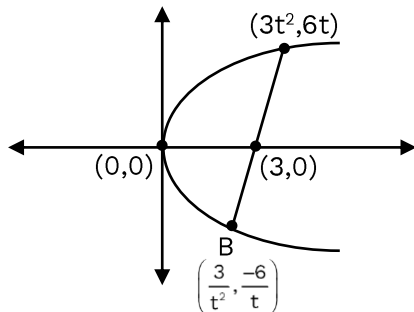

$$y^2 = 4(3)x; a = 3 \quad \Rightarrow \text{focus} = (3,0)$$

$$t_1 t_2 = -1$$

$$A = 3t^2, 6t$$

$$\text{then } B = \frac{3}{t^2}, \frac{-6}{t}$$

AB = length of focal chord

$$= a(t_1 - t_2)^2$$

$$= 3\left(t + \frac{1}{t}\right)^2 = 15$$

$$3\left(t + \frac{1}{t}\right)^2 = 15$$

$$t + \frac{1}{t} = \sqrt{5}$$

$$t - \frac{1}{t} = \sqrt{\left(t + \frac{1}{t}\right)^2 - 4}$$

$$t - \frac{1}{t} = 1$$

$$m_{AB} = \frac{6t - \frac{6}{t}}{3t^2 - \frac{3}{t^2}}$$

$$m_{AB} = \frac{2}{t - \frac{1}{t}}$$

$$\therefore m_{AB} = 2$$

Equation of AB: $y - 0 = 2(x - 3)$

$$y = 2x - 6$$

$$2x - y - 6 = 0$$

$$\text{Distance from origin, } P = \frac{|2(0) - 0 - 6|}{\sqrt{2^2 + 1}} = \frac{6}{\sqrt{5}}$$

$$10P^2 = \frac{10 \times 36}{5} = 72$$

20. Shortest distance between lines $\frac{x+1}{-2} = \frac{y}{2} = \frac{z-1}{1}$ and $\frac{x-5}{2} = \frac{y-2}{-3} = \frac{z-1}{1}$ is $\frac{38k}{6\sqrt{5}}$, find

$$\int_0^k [x^2] dx$$

Ans. $(5 - \sqrt{2} - \sqrt{3})$

Sol. $S.D = \frac{(6\hat{i} + 2\hat{j}) \cdot (5\hat{i} + 4\hat{j} + 2\hat{k})}{\sqrt{45}} = \frac{38}{3\sqrt{5}} = \frac{38k}{6\sqrt{5}} \Rightarrow k = 2$

$$\int_0^2 [x^2] dx = \int_1^{\sqrt{2}} dx + \int_{\sqrt{2}}^{\sqrt{3}} 2dx + \int_{\sqrt{3}}^2 3dx = (\sqrt{2} - 1) + 2(\sqrt{3} - \sqrt{2}) + 3(2 - \sqrt{3}) = 5 - \sqrt{2} - \sqrt{3}$$

21. $y = y(x)$ is a solution of the differential equation

$$(x^4 + 2x^3 + 3x^2 + 2x + 2) dy - (2x^2 + 2x + 3) dx = 0. \text{ If } y(0) = \frac{\pi}{4}. \text{ Find } y(-1)$$

Ans. $(-\frac{\pi}{4})$

Sol. $\frac{dy}{dx} = \frac{2x^2 + 2x + 3}{x^4 + 2x^3 + 3x^2 + 2x + 2}$

$$\frac{dy}{dx} = \frac{(x^2 + 1) + (x^2 + 2x + 2)}{(x^2 + 1)(x^2 + 2x + 2)} = \frac{1}{(x+1)^2 + 1} + \frac{1}{x^2 + 1}$$

Hence $y = \tan^{-1}x + \tan^{-1}(x+1) + c$

$$\text{If } y(0) = \frac{\pi}{4} \Rightarrow c = 0$$

$$\text{So } y(-1) = -\frac{\pi}{4}$$

22. Curve $y = 1 + 3x - 2x^2$ and $y = \frac{1}{x}$ intersects at point $(\frac{1}{2}, 2)$ then area enclosed between curve

is $\frac{1}{24}(\ell\sqrt{5} + m) - n \log_e(1 + \sqrt{5})$ then find the value of $\ell + m + n$ is

Ans. (30)

Sol. $1 + 3x - 2x^2 = \frac{1}{x}$

$$\Rightarrow x + 3x^2 - 2x^3 = 1$$

$$\Rightarrow 2x^3 - 3x^2 - x + 1 = 0$$

$$\Rightarrow 2x^3 - x^2 - 2x^2 + x - 2x + 1 = 0$$

$$\Rightarrow (2x-1)x^2 - x(2x-1) - 1(2x-1) = 0$$

$$\Rightarrow (2x-1)(x^2 - x - 1) = 0$$

$$x = \frac{1}{2} \quad \text{or} \quad x^2 - x - 1 = 0$$

$$x = \frac{1 \pm \sqrt{5}}{2}$$

$$x = \frac{1+\sqrt{5}}{2}, \frac{1-\sqrt{5}}{2}$$

$$\text{Area} = \int_{1/2}^{\frac{\sqrt{5}+1}{2}} \left((-2x^2 + 3x + 1) - \frac{1}{x} \right) dx$$

$$= \left[-\frac{2x^3}{3} + \frac{3x^2}{2} + x - \ln x \right]_{1/2}^{\frac{\sqrt{5}+1}{2}}$$

$$= \left(-\frac{2}{3} \left(\frac{\sqrt{5}+1}{2} \right)^3 + \frac{3}{2} \left(\frac{\sqrt{5}+1}{2} \right)^2 + \left(\frac{\sqrt{5}+1}{2} \right) - \ln \left(\frac{\sqrt{5}+1}{2} \right) \right)$$

$$- \left(-\frac{1}{12} + \frac{3}{8} + \frac{1}{2} - \ln \frac{1}{2} \right)$$

$$= -\frac{1}{12} (5\sqrt{5} + 1 + 3\sqrt{5}(\sqrt{5} + 1)) + \frac{3}{8} (6 + 2\sqrt{5}) + \frac{\sqrt{5} + 1}{2}$$

$$- \ln(\sqrt{5} + 1) + \ln 2 - \left(\frac{-2 + 9 + 12}{24} \right) - \ln 2$$

$$= -\frac{1}{12} (16 + 8\sqrt{5}) + \frac{3}{4} (3 + \sqrt{5}) + \frac{\sqrt{5} + 1}{2} - \frac{19}{24} - \ln(\sqrt{5} + 1)$$

$$= \frac{1}{24} [-32 - 16\sqrt{5} + 54 + 18\sqrt{5} + 12\sqrt{5} + 12 - 19] - \ln(\sqrt{5} + 1)$$

$$= \frac{1}{24} [15 + 14\sqrt{5}] - \ln(\sqrt{5} + 1)$$

So $l = 14$, $m = 15$, $n = 1$

Hence $l + m + n = 14 + 15 + 1 = 30$

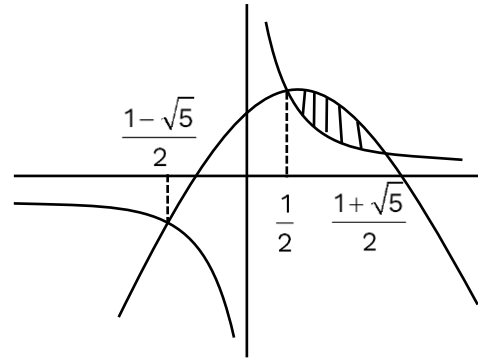

PHYSICS

1. A metallic wire of uniform mass density having mass M and length l is bent to form a semicircle. A point mass m is kept at the centre of the semicircle. Find the gravitational force experienced by m .

Ans. $\frac{2\pi GMm}{L^2}$

Sol. $r = \frac{L}{\pi}$

$$dg = \frac{Gdm}{r^2} \sin\theta$$

$$= \frac{GM}{r^2 L} rd\theta \sin\theta$$

$$= \frac{G}{g} = \frac{GM}{r} \cdot \frac{M}{L} \int_0^\pi \sin\theta d\theta$$

$$g = \frac{GM}{rL} (2)$$

$$F = mg$$

$$= m^2 \frac{GM}{rL}$$

$$= \frac{2GMm}{L} \cdot \frac{\pi}{L}$$

$$= \frac{2\pi GMm}{L^2}$$

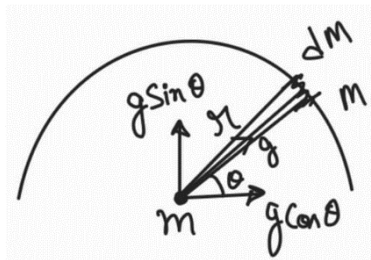

2. 5 convex lens are kept together each having power of 25 D. Find the focal length.

Ans. 0.8 cm

Sol. $P_{eq} = P \times 5$

$$= 25 \times 5$$

$$= 125D$$

$$\frac{1}{f_{eq}} = 125 \text{ m}^{-1}$$

$$= \frac{100}{125} \text{ cm}$$

$$= \frac{4}{5} \text{ cm}$$

$$= 0.8 \text{ cm}$$

3. Position of a particle is related to time as given equation

$$x = t^4 + 6t^2 + 2t$$

Find its acceleration at $t = 5$ sec.

Ans. 480 m/s^2

Sol. $V = \frac{dx}{dt}$

$$V = 4t^3 + 12t + 2$$

$$a = \frac{dV}{dt}$$

$$= 12t^2 + 12$$

At $t = 5$ sec

$$a = 12 \times 25 + 12 \times 1$$

$$= 300 + 12$$

$$= 480 \text{ m/s}^2$$

4. A body moving with constant acceleration covers 102.5 m in n^{th} second of its motion and covers 115.0 m in $(n + 2)^{\text{th}}$ second then find its acceleration.

Ans. 6.25 m/s²

Sol. Let, acceleration = a (constant)

$$S_{n^{\text{th}}} = u + \frac{a}{2}[2n - 1] = 102.5 \quad \dots(i)$$

$$S_{(n+2)^{\text{th}}} = u + \frac{a}{2}[2(n + 2) - 1] = 115$$

$$\Rightarrow u + \frac{a}{2}[2n + 3] = 115 \quad \dots(ii)$$

by using (i) and (ii)

$$102.5 - \frac{a}{2}[2n - 1] + \frac{a}{2}[2n + 3] = 115$$

$$\Rightarrow 102.5 + \frac{a}{2} + \frac{3a}{2} = 115$$

$$\Rightarrow 2a = 115 - 102.5$$

$$a = \frac{12.5}{2} = 6.25 \text{ m / s}^2$$

5. A particles of mass m dropped from height h above the ground. After collision, rises to height h/2, Then loss in energy during collision and speed of particle just before collision respectively are.

(1) 50%, $\sqrt{2gh}$ (2) 40%, $\sqrt{2gh}$ (3) 50%, \sqrt{gh} (4) 40%, \sqrt{gh}

Ans. (1)

Sol. $\Delta E = mg \frac{h}{2} - mgh = -mg \frac{h}{2}$

i.e. 50% loss in energy

$$v = \sqrt{2gh}$$

6. If the electric field vector at a point in an electromagnetic wave is given by

$$\vec{E} = 40 \cos \omega \left(t - \frac{z}{c} \right) \hat{i} \text{ then corresponding } \vec{B} \text{ will be:}$$

Sol. $\vec{E} = 40 \cos \omega \left(t - \frac{z}{c} \right) \hat{i}$

$$|\vec{E}| = 40 \cos \omega \left(t - \frac{z}{c} \right)$$

$$\frac{|\vec{E}|}{|\vec{B}|} = c$$

$$|\vec{B}| = \frac{40}{c} \cos \omega \left(t - \frac{z}{c} \right); \text{ also } \vec{E} \cdot \vec{B} = 0$$

7. Infinite charge sheet in xy plane of surface charge density σ and infinite long wire of linear charge density λ placed at (0, 0, 4) and $\sigma = 2\lambda$. Then net electric field (0, 0, 2).

Ans. $E_{\text{net}} \Rightarrow \frac{\lambda}{\epsilon_0} \left[\frac{2\pi r - 1}{2\pi r} \right] \text{ N/C}$

Sol. Given : $\sigma = 2\lambda$

$$E_{\text{net}} = \frac{\sigma}{2\epsilon_0} - \frac{2K\lambda}{r}$$

$$E_{\text{net}} = \frac{2\lambda}{2\epsilon_0} - \frac{2\lambda}{4\pi\epsilon_0 r}$$

$$E_{\text{net}} = \frac{2\lambda}{2\epsilon_0} - \frac{2\lambda}{4\pi\epsilon_0 r}$$

$$\Rightarrow \frac{\lambda}{\epsilon_0} \left[\frac{2\pi r - 1}{2\pi r} \right] \text{N/C}$$

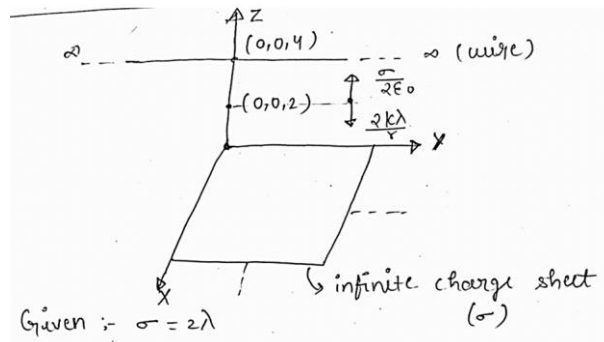

8. A hollow cylinder and solid sphere of same mass and radius are rolling with same initial velocity v on a rough inclined plane. Find the ratios of their kinetic energies and maximum height reached by them.

Ans. $\frac{10}{7}$

Sol. $K_{\text{cylinder}} = \frac{1}{2}MV^2 + \frac{1}{2}I_{\text{cm}}\omega^2 = \frac{1}{2}MV^2 + \frac{1}{2}(MR^2)\left(\frac{V}{R}\right)^2$
 $= MV^2$

$$K_{\text{sphere}} = \frac{1}{2}I_{\text{cm}}\omega^2 + \frac{1}{2}MV^2$$

$$= \frac{1}{2}\left(\frac{2}{5}MR^2\right)\left(\frac{V}{R}\right)^2 + \frac{1}{2}MV^2$$

$$= \frac{1}{5}MV^2 + \frac{1}{2}MV^2$$

$$= \frac{7}{10}MV^2$$

$$\Rightarrow \frac{K_{\text{cylinder}}}{K_{\text{sphere}}} = \frac{10}{7}$$

At top point kinetic energy will convert into potential energy

$$\frac{Mgh_{\text{cylinder}}}{Mgh_{\text{sphere}}} = \frac{10}{7}$$

$$\Rightarrow \frac{h_{\text{cylinder}}}{h_{\text{sphere}}} = \frac{10}{7}$$

9. In given equation $y = 2A \sin\left(\frac{2\pi nt}{\lambda}\right) \cos\left(\frac{2\pi x}{\lambda}\right)$. Find the dimension of n .

Ans. $[n] = [L^1T^{-1}]$

Sol. $[n] \Rightarrow \frac{[2\pi nt]}{[\lambda]} + M^0L^0T^0$

$$\frac{[n][T^1]}{[L^1]} = M^0L^0T^0$$

$$[n] = [L^1T^{-1}]$$

10. When a conducting platinum wire is placed in ice, its resistance is 8Ω and when placed in steam it is 10Ω . Find the resistance of wire at 400°C .

Ans. 8.8Ω

Sol. $R_T = R_0(1 + \alpha\Delta T)$

$$R_0 \text{ at } 0^\circ \Rightarrow 8\Omega$$

$$R_T \text{ at } 100^\circ\text{C} \rightarrow 10\Omega$$

$$10 = 8(1 + \alpha(100))$$

$$\frac{10}{8} = 1 + 100\alpha$$

$$\left(\frac{10}{8} - 1\right) \times \frac{1}{100} = \alpha$$

$$\alpha = \frac{2}{8} \times \frac{1}{100}$$

$$\alpha = \frac{1}{400}$$

R at 40°

$$R = R_0(1 + \alpha\Delta T)$$

$$= 8 \left(1 + \frac{1}{400} \times 40\right)$$

$$= 8 \left(1 + \frac{1}{10}\right)$$

$$= \frac{11 \times 8}{10}$$

$$R = 8.8\Omega$$

11. Fractional error in image distance and object distance are $\frac{\Delta v}{v}$ and $\frac{\Delta u}{u}$ then find the fractional error in focal length of the given spherical mirror.

Ans. $\Rightarrow \frac{df}{f} = \frac{uv}{u+v} \left[\frac{dv}{v^2} + \frac{du}{u^2} \right]$

Sol. $\frac{1}{f} = \frac{1}{v} + \frac{1}{u}$

$$\frac{1}{f} = \frac{u+v}{uv}$$

$$f = \frac{uv}{u+v}$$

$$\Rightarrow -\frac{1}{f^2} df = -\frac{dv}{v^2} - \frac{du}{u^2}$$

$$\Rightarrow \frac{df}{f} = f \left[\frac{1}{v} \frac{dv}{v} + \frac{1}{u} \frac{du}{u} \right]$$

$$\Rightarrow \frac{df}{f} = \frac{uv}{u+v} \left[\frac{dv}{v^2} + \frac{du}{u^2} \right]$$

12. Instantaneous current in a circuit is zero. In which of the options voltage will be maximum.

(a) L

(b) C

(c) R

(d) LC

(1) ABD

(2) B

(3) BC

(4) D

Ans. (1)

Sol. Phase difference between current and voltage is 90° .
So, possible circuit are (A), (B) and (D).

13. x and y coordinates of a body performing some motion is given as:

$$x = 3 + 4t$$
$$y = 3t^2 + 4t$$

Identify the trajectory of motion.

(1) Parabola (2) Circular (3) Straight line (4) Hyperbola

Ans. (1)

Sol. $x = 3 + 4t \Rightarrow t = \frac{x-3}{4}$ (1)

$y = 3t^2 + 4t$ (2)

equation (1) in (2)

$$y = 3 \frac{(x-3)^2}{16} + 4 \frac{(x-3)}{4}$$

$$\Rightarrow y = \frac{3}{16} (x^2 + 9 - 6x) + (x - 3)$$

$$\Rightarrow y = \frac{1}{16} [3x^2 + 27 - 18x + 16x - 48]$$

$$y = \frac{1}{16} [3x^2 - 2x - 21]$$

\Rightarrow it is quadratic in x

\Rightarrow its trajectory is parabola.

14. Choose the correct graph for kinetic energy vs r for an electron revolving around a infinite line of charge.

Ans. Theoretical

Sol. Net force acting towards centre = $\frac{mv^2}{r}$

$$F = q \times E$$

$$F = e \times 2k \frac{\lambda}{r}$$

$$\Rightarrow \frac{mv^2}{r} = (e) \left(\frac{2k\lambda}{r} \right)$$

$$mv^2 = 2k\lambda \times e$$

$$\Rightarrow KE = 2k\lambda e$$

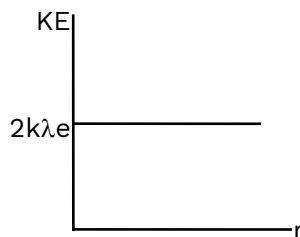

15. Pressure vs temperature graph is given for gas of different density. Compare ρ_1 , ρ_2 and ρ_3 ?

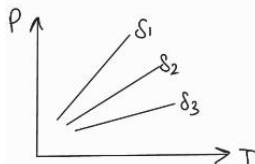

Ans. $\rho_1 > \rho_2 > \rho_3$

Sol. $PM = \rho RT$

$$\rho = \frac{PM}{RT}$$

$$\rho \propto \frac{P}{T}$$

$\rho \propto$ slope

Hence $\rho_1 > \rho_2 > \rho_3$

16. Work done to expand the bubble of diameter 7 cm and surface tension 40 dyne/cm is 36960 erg. Find the radius of the expanded bubble?

Ans. 14 cm

Sol. Surface energy = T (area)
Bubble has tw surface of interface

$$E_i = 2TS_i$$

$$E_f = 2TS_f$$

$$\Rightarrow \text{Work done} = E_f - E_i$$

$$\Rightarrow 36960 = 2[TS_f - TS_i]$$

$$\Rightarrow 3690 = T\Delta S \times 2$$

$$\Rightarrow \Delta S = \frac{36960}{40 \times 2}$$

$$\Rightarrow \Delta S = 462 \text{ cm}^2$$

$$S_f - S_i = 462$$

$$\Rightarrow 4\pi r_f^2 = 462 + 4\pi r_i^2$$

$$\Rightarrow r_f^2 = \frac{1}{4\pi} \left[462 + 4\pi \times \left(\frac{7}{2} \right)^2 \right]$$

$$r_f^2 = \frac{1}{4\pi} \left[462 + 4\pi \times \frac{49}{4} \right]$$

$$= \frac{462 \times 7}{4 \times 22} + \frac{49}{4}$$

$$= r_f^2 = \frac{196}{4} = 49$$

$$r_f = 7 \text{ cm}$$

$$\text{diameter} = 7 \times 2 = 14 \text{ cm}$$

17. De-Broglie wavelength of electron moving from $n = 4$ to $n = 3$ of a hydrogen is $b(\pi a)$; Where a is bohr radius of the hydrogen atom. Find the value of b .

Ans. $b = 2$

Sol. $E = \frac{hc}{\lambda}, mvr = \frac{nh}{2\pi}$

$$\lambda = \frac{h}{mv} = \frac{2\pi r}{n}$$

$$(\lambda_1)_{n=4} = \frac{(2\pi)(a_0 n^2)}{n}$$

$$(\lambda_1)_{n=4} = (2\pi)(a_0 n) = 8\pi a_0$$

$$(\lambda_2)_{n=3} = 6\pi a_0$$

$$\Delta\lambda = \lambda_1 - \lambda_2 = 8\pi a_0 - 6\pi a_0$$

$$\Delta\lambda = 2\pi a_0$$

Therefore $b = 2$

18. An elastic string under tension of 3N has a length of 'a'. If length is 'b' then tension is 2N. Find tension when length is $(3a - 2b)$.

Ans. $\frac{5F}{K}$

Sol. $F = kx$

$$3F = Ka \Rightarrow a = \frac{3F}{K}$$

$$2F = Kb \Rightarrow b = \frac{2F}{K}$$

$$\text{Now, } 3a - 2b = \frac{9F}{K} - \frac{4F}{K} = \frac{5F}{K}$$

19. An electron projected inside the solenoid along its axis which carries constant current, then its trajectory would be:

Ans. Straight line

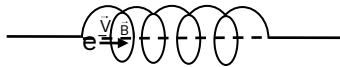
Sol. 

$$\vec{F} = q(\vec{V} \times \vec{B})$$

\vec{B} and \vec{V} are parallel at axis of solenoid so, their cross product will be zero

i.e. $\vec{F} = 0$

So, electron will move with constant velocity in a straight line.

20. Current as a function of time is given as $i = 6 + \sqrt{56} \sin\left(100t + \frac{\pi}{3}\right)$ A. Find rms value of current.

Ans. 8 A

Sol.

$$i_{\text{rms}} = \sqrt{6^2 + \frac{(\sqrt{56})^2}{2}}$$

$$= \sqrt{36 + 28}$$

$$= \sqrt{64}$$

$$= 8 \text{ A}$$

21. In Celsius the temperature of a body increases by 40°C . The increasing temperature on Fahrenheit scale is:

Ans. 72°F

Sol. $T_F = \frac{9}{5}T_C + 32$

$$\Delta T_f = \frac{9}{5} \Delta T_c$$

$$\Rightarrow \Delta T_f = \frac{9}{5} \times 40$$

$$\Rightarrow \Delta T_f = 72^\circ \text{ F}$$

22. Force on a particle varies linearly with time(t) ($F \propto t$). Then select correct acceleration vs time graph.

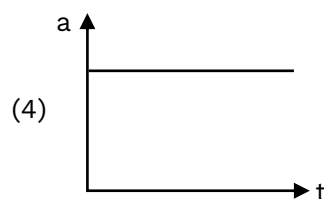
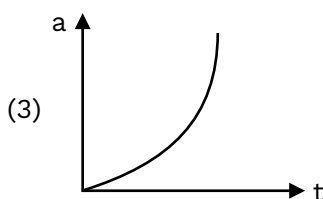
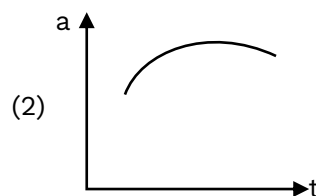
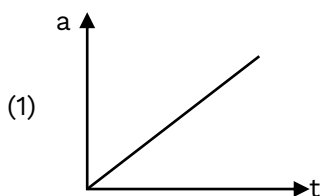

Ans. $\Rightarrow a \propto t$

Sol. $F = ma \Rightarrow a = \frac{F}{m}$

$\Rightarrow a \propto t$

23. Which graph correctly represents the photo current (i) vs stopping potential (V_s) for the same frequency but different intensity? (Here $I_1 > I_2$)

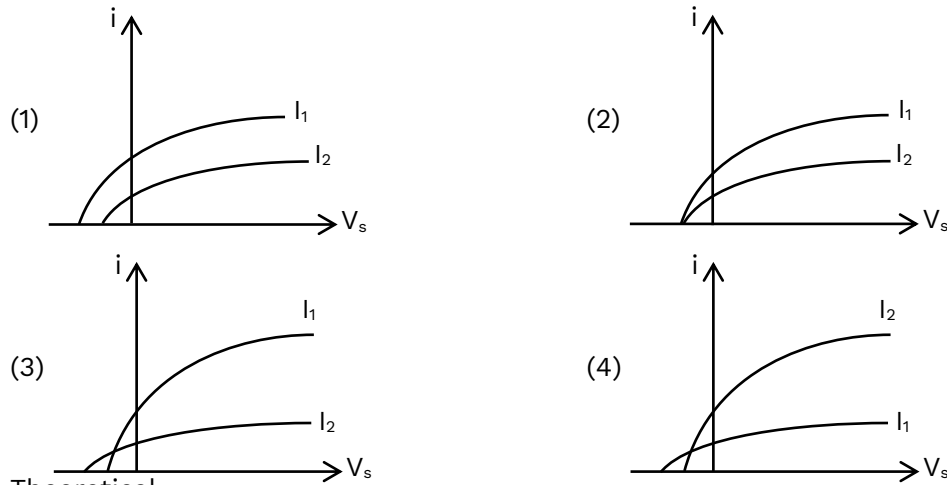

Ans. Theoretical

24. A cubical arrangement of 12 resistors each having resistance R is shown. Find I shown in the given circuit.

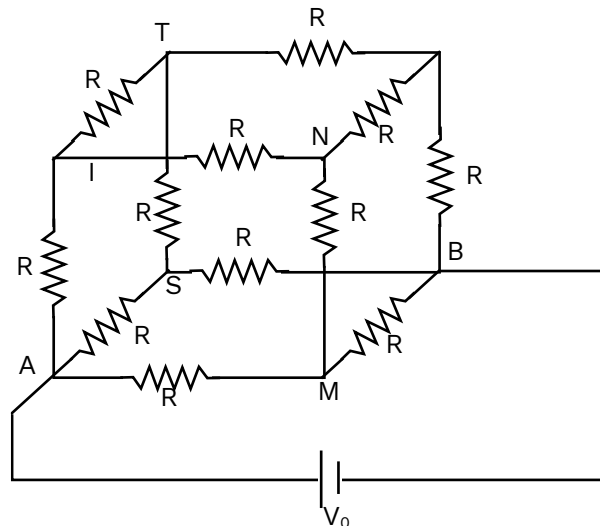

Ans. $\frac{V_0}{6R}$

Sol. $\frac{1}{R_{eq}} = \frac{1}{3R} + \frac{1}{R} = \frac{4}{3R}$

$R_{eq} = \frac{3R}{4}$

$\Rightarrow V_0 = IR_{eq}$

$\Rightarrow I = \frac{4V_0}{3R}$

So, $I_1 + I_2 = I$

\Rightarrow in parallel combination, current is divided into inverse ratio of resistance

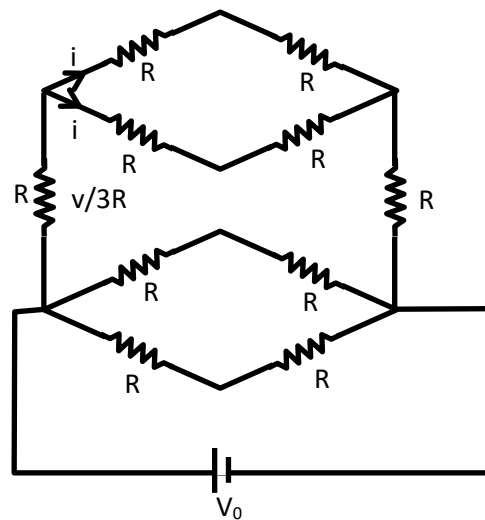

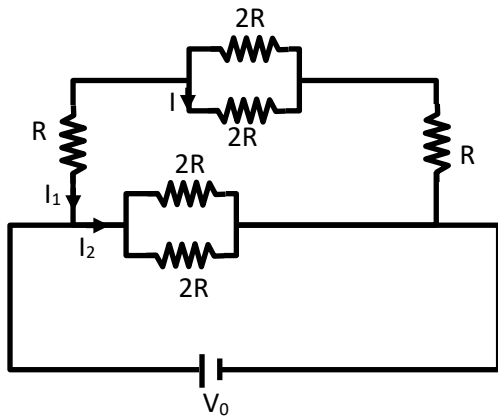

$$\Rightarrow \frac{I_1}{I_2} = \frac{1}{3}$$

$$\Rightarrow I_1 + 3I_1 = I \Rightarrow I_1 = \frac{1}{4}I = \frac{V_0}{3R}$$

Now, I_1 gets divided equally in both branches

$$i = \frac{I_1}{2} = \frac{V_0}{3R} \times \frac{1}{2} \Rightarrow i = \frac{V_0}{6R}$$

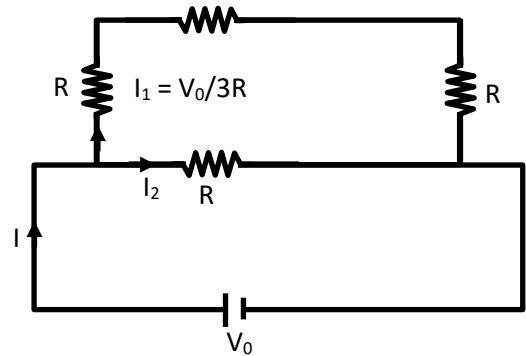

25. A wooden block is initially at rest on a smooth surface. Now a horizontal force is applied on the block which increases linearly with time. The acceleration time ($a-t$) graph for the block would be:

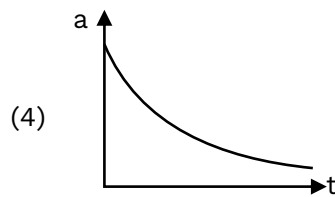
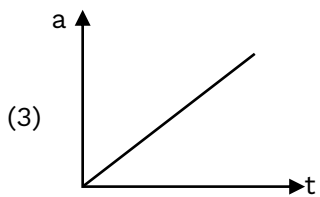
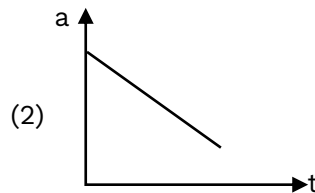
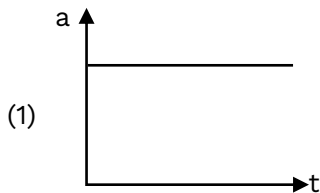
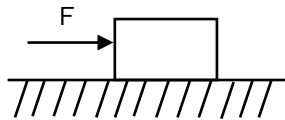

Ans. $F = \frac{k}{m}t$

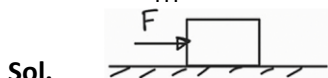

This horizontal force increases linearly with time

$$F \propto t$$

$$F = kt + c \quad (\because F = ma)$$

$$a = \frac{k}{m}t + \frac{c}{m}$$

if, $\frac{c}{m} = 0$

$$\tan\theta = \frac{k}{m}$$

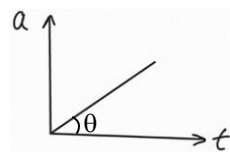

then :

$$\Rightarrow F = kt$$

$$\Rightarrow a = F = \frac{k}{m}t$$

26. Find R_{eq} ?

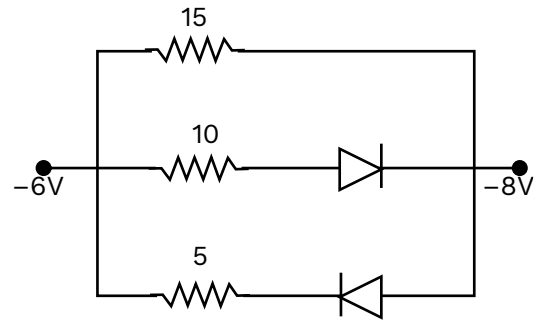

Sol. Below diode is in reverse bias so no current flow through it circuit looks like.

$$R_{eq} = \frac{5}{2} = 2.5\Omega$$

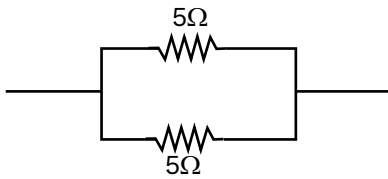

CHEMISTRY

1. Which of the following is the correct structure of L-Glucose

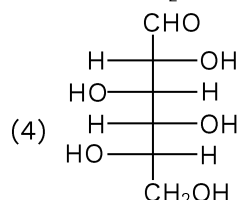
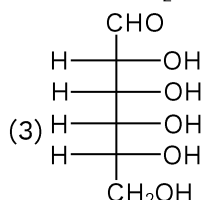
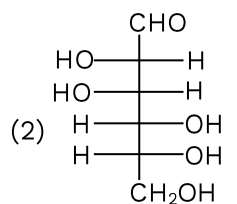
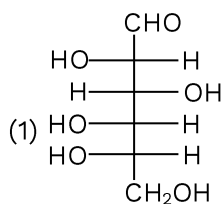

Ans. (1)

Sol. Structure based

2. How many structural isomer are there in C_7H_{16}

- (1) 5 (2) 6 (3) 8 (4) 9

Ans. (4)

Sol. 9 structural isomers are possible of C_7H_{16}

3. Which of the following has the maximum dipole moment

- (1) NH_3 (2) NF_3 (3) PCl_5 (4) CH_4

Ans. (1)

Sol. NH_3 has maximum dipole moment

4. Which of the following show only one oxidation state except it's elemental state

- (1) Ti (2) Sc (3) Co (4) Ni

Ans. (2)

Sol. Sc show only +3 oxidation state.

5. Number of species having sp^3 hybridised central atom

- NO_3^- BCl_3 ClO_2^- ClO_3^-

Ans. (02.00)

Sol. Cl atom in ClO_2^- and ClO_3^- molecule is sp^3 hybridised.

6. Number of complexes having even number of unpaired electron in d-orbital.

- $[\text{Cu}(\text{H}_2\text{O})_6]^{2+}$, $[\text{Fe}(\text{H}_2\text{O})_6]^{3+}$, $[\text{Cr}(\text{H}_2\text{O})_6]^{2+}$, $[\text{Ni}(\text{H}_2\text{O})_6]^{2+}$

Ans. (02.00)

Sol. All are octahedral complex

Complex	Number of unpaired electron
$[\text{Cu}(\text{H}_2\text{O})_6]^{2+}$	1
$[\text{Fe}(\text{H}_2\text{O})_6]^{3+}$	5
$[\text{Cr}(\text{H}_2\text{O})_6]^{2+}$	4

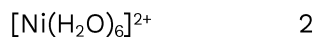

7. If emf of hydrogen electrode at 25°C is zero pure water then pressure of H_2 in bar

- (1) 10^{-14} (2) 10^{-7} (3) 1 (4) 0.5

Ans. (1)

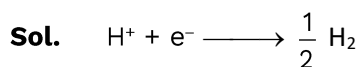

$$\varepsilon = 0 - \frac{0.059}{1} \log \frac{(P_{\text{H}_2})^{1/2}}{10^{-7}}$$

$$\frac{(P_{\text{H}_2})^{1/2}}{10^{-7}} = 1$$

$$P_{\text{H}_2} = 10^{-14}$$

8. Pressure v/s temperature graph of an ideal gas of equal number of moles of different density is given below:

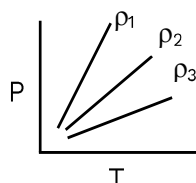

- (1) $\rho_1 = \rho_2 = \rho_3$ (2) $\rho_1 > \rho_2 > \rho_3$ (3) $\rho_1 < \rho_2 < \rho_3$ (4) $\rho_1 > \rho_2 < \rho_3$

Ans. (2)

Sol. $P = \frac{R\rho}{M} T$

$$\text{Slope} = \frac{R\rho}{M} \propto \rho$$

$$\rho_1 > \rho_2 > \rho_3$$

9. Total number of species having single unpaired electron in NO , $\overline{\text{CN}}$, O_2^- , O_2^{2-} , O_2

Ans. (02.00)

Sol.	NO	total $e^- = 15$	Unpaired $e^- = 1$
	CN^-	total $e^- = 14$	Unpaired $e^- = 0$
	O_2^-	total $e^- = 17$	Unpaired $e^- = 1$
	O_2^{2-}	total $e^- = 18$	Unpaired $e^- = 0$
	O_2	total $e^- = 16$	Unpaired $e^- = 2$

10. Which of the following is the correct order of 1st ionisation enthalpy?

- (1) $\text{Be} < \text{B} < \text{O} < \text{F} < \text{N}$ (2) $\text{B} < \text{Be} < \text{O} < \text{N} < \text{F}$
 (3) $\text{B} < \text{Be} < \text{N} < \text{F} < \text{O}$ (4) $\text{Be} < \text{B} < \text{N} < \text{F} < \text{O}$

Ans. (2)

Sol. $\text{Be} > \text{B} < \text{N} > \text{O} < \text{F}$

$$2s^2 \quad 2p^1 \quad 2p^3 \quad 2p^4 \quad 2p^5 \rightarrow \text{electronic configuration}$$

Correct order

B < Be < O < N < F

11. For any reaction $K = \frac{K_1 K_2}{K_3}$ and $E_{a_1} = 400, E_{a_2} = 300, E_{a_3} = 200$ hence E_{overall} ?

(1) 400 (2) 200 (3) 500 (4) 600

Ans. (3)

Sol. $E_{\text{overall}} = E_{a_1} + E_{a_2} - E_{a_3}$
 $= 400 + 300 - 200 = 500$

12. If weight of NaCl in 500ml aqueous solution is 5.85 gm hence calculate the molarity?

Ans. (00.20)

Sol. $[\text{NH}_3] = \frac{n}{v} = \frac{5.85 / 58.5}{0.5} = 0.2\text{M}$

13. 2M, 2ml solution of KMnO_4 is neutralised with 20 ml $\text{H}_2\text{C}_2\text{O}_4$. Calculate molarity of $\text{H}_2\text{C}_2\text{O}_4$

Ans. (00.50)

Sol. $\text{MnO}_4^- + \text{C}_2\text{O}_4^{2-} \xrightarrow{\text{H}^+} \text{Mn}^{2+} + \text{CO}_2$
 $n_f = 5$ $n_f = 2$
 $2 \times 5 \times 2 = M \times 2 \times 20$
 $M = 0.5 \text{ M}$

14. De-Broglie wavelength of e^- 4th orbit of H-Atom is $x\pi r_0$, where r_0 = bohr's 1st orbit radius of H-Atom x is _____

Ans. (8)

Sol. $4\lambda = 2\pi r_4$
 $\lambda = \frac{2\pi}{4} r_0 \times 4^2$
 $= 8\pi r_0$

15. Among which of the following decreasing order of basic strength will be

(i) OH^- (ii) H^- (iii) HCOO^- (iv) CH_3COO^-

(v) —OR

(1) II > V > II > I > IV (2) II > V > I > IV > III

(3) III > VI > I > V > II (4) V > I > VI > II > III

Ans. (2)

Sol. The order of basic strength is as follows :

$\text{H}^- > \text{—OR} > \text{OH}^- > \text{CH}_3\text{COO}^- > \text{HCOO}^-$

16. What type of electrode is calomel?

(1) redox electrode (2) metal-metal insoluble salt-its anion

(3) gas-ion (4) metal-metal ion

Ans. (2)

Sol. metal-metal insoluble salt-its anion.

17. Total number of elements which do not use all valence electrons in bonding as per their group number among them Q, S, E, N, Al, C, Si

Ans. (03.00)

Sol. Valance Electron

<u>Q</u>	6
S	6
<u>E</u>	7
<u>N</u>	5
Al	3
C	4
Si	4

18. Identify the suitable reagents X and Y for given below reaction respectively

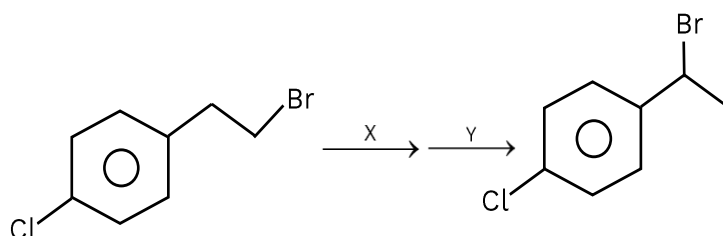

- (1) dil. NaOH/20° ; HBr/CH₃-COOH (2) dil. NaOH/20° ; Br₂/CH₃-COOH
 (3) Alcoholic NaOH/80° ; HBr/CH₃COOH (4) Alcoholic NaOH/80° ; HBr/Peroxide

Ans. (3)

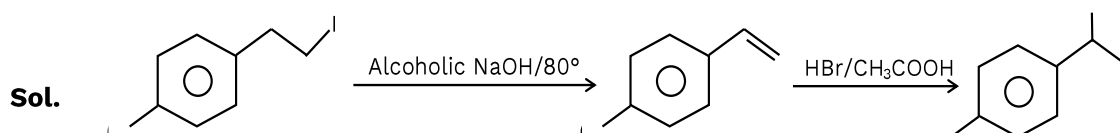

19. Compare ligand strength of F⁻, OH⁻, SCN⁻, CO

- (1) CO > OH⁻ > F⁻ > SCN⁻ (2) CO > F⁻ > OH⁻ > SCN⁻
 (3) SCN⁻ > OH⁻ > F⁻ > CO (4) F⁻ > CO > OH⁻ > SCN⁻

Ans. (1)

Sol. SFL (Strong Field Ligand) > WFL (Weak Field Ligand)

C/N/P O/Halogens/S

20. Which of the following compound will not give the test of nitrogen by the help of lassaigne's extract?

- (1) Hydrazine (2) Phenyl hydrazine
 (3) Glycine (4) Urea

Ans. (1)

Sol. Hydrazine (NH₂NH₂) does not contain carbon On fusion with Na metal, it cannot form NaCN. So hydrazine does not show lassaigne's test.



Find the sum of spin only magnetic moment of central metal ion in both the products.
(nearest integer)

Ans. (04.00)

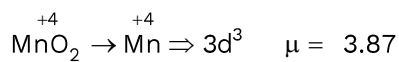
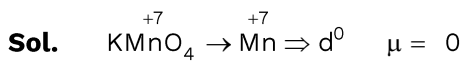

nearest integer = 4

22. During the test of group IV NH_4Cl is added with NH_4OH why?

- (1) to increase the concentration of OH^- ion
- (2) to decrease the concentration of OH^- ion
- (3) to increase the concentration of H^+ ion
- (4) to decrease the concentration of H^+ ion

Ans. (2)

Sol. NH_4Cl is added with NH_4OH to decrease the concentration of OH^- ion in order to avoid precipitation of further group elements.

23. **Statement-I:** α -H is responsible for carbonyls giving aldol

Statement-II: Benzaldehyde & ethanal show cross aldol

- (1) Both statements are correct
- (2) statements-I is correct and statement-II is incorrect
- (3) statements-II is correct and statement-I is incorrect
- (4) Both statements are incorrect

Ans. (1)

Sol. **Statement-I:** Aldol condensation is proceed through α -hydrogen \Rightarrow True

Statement-II: Ethanal have α -hydrogen hence it shows cross aldol \Rightarrow True

24. What is the correct product in below given reaction

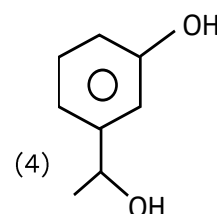
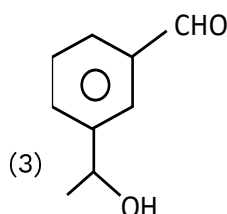
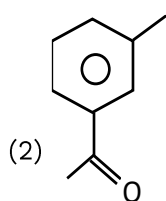
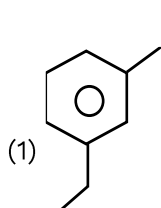
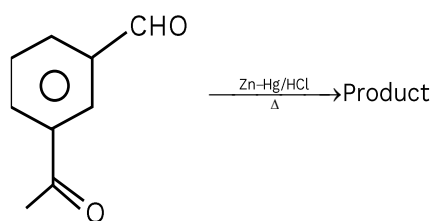

Ans. (1)

Sol. Clemmensen Reduction is used to reduce aldehyde & ketone into its respective alkane.

